

# PARTS BOOK

FOR

**BROTHER DB2-B715** -100, -200,  
-400, -500

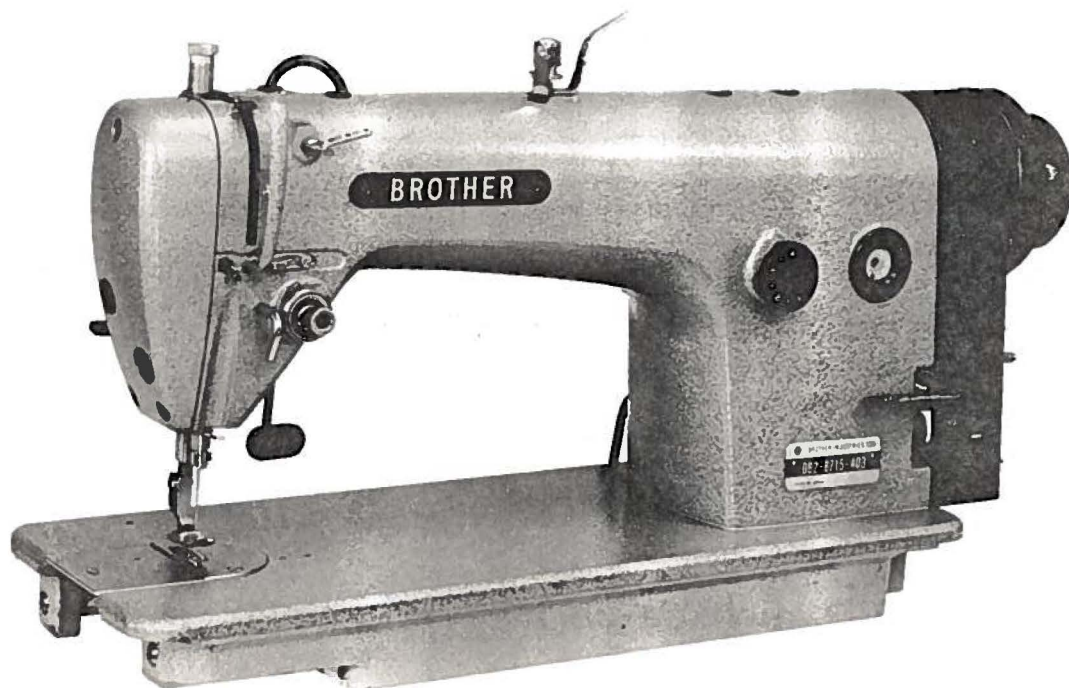



High Speed Lock Stitcher with Automatic Thread Trimmer

**BROTHER INDUSTRIES, LTD.**



**NAGOYA, JAPAN**

From the library of: Superior Sewing Machine & Supply LLC

## Notes for using this parts book

1. If the symbol  is found in the "Parts No." column or the "Assembly No." column, refer to the different parts list on page 18.
2. The symbol  in the "Parts No." column indicates that the parts is not available for supply. If, however, there is a number in the "Assembly No." column, the parts can be ordered as an assembly. Please, therefore, order by using the Assembly No.
3. This book was prepared based on information available in November, 1978.
4. Parts are subject to changes in design without prior notice.



## Anmerkungen zum Gebrauch dieses Stücklistebuches

1. Dieses Zeichen  in der Spalte "Parts No. (Teilnummer)" oder "Assembly No. (Gerätesatznummer)" verweist auf die Gesonderte Stückliste auf Seite 18.
2. Dieses Zeichen  in der Spalte "Teilnummer" bedeutet, daß dieser Teil nicht lieferbar ist. Wenn jedoch in der Spalte "Gerätesatznummer" eine Nummer steht, kann dieser Teil als ein Geräteteilsatz bestellt werden. Bestellen Sie daher bitte mit dieser Gerätesatznummer.
3. Dieses Buch basiert auf den Informationen vom November, 1978.
4. Modelländerungen sind vorbehalten.

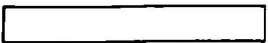
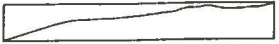
## Notes sur l'utilisation de ce manuel de pièces détachées

1. Si le symbole  se trouve dans la colonne "Parts No. (N° de pièce)" ou dans la colonne "Assembly No. (N° jeu de pces)", veuillez vous référer à la liste de pièces annexée page 18.
2. Le symbole  dans la colonne "N° de pièce" signifie que la pièce ne peut être fournie. Si, dans la colonne "N° jeu de pces", il y a un numéro de nomenclature, la pièce peut être commandée comme faisant partie d'un jeu de pièces. Donc, pour toute commande, veuillez spécifier le N° de jeu de pièces.
3. Ce manuel a été fait d'après les renseignements valables au mois de Novembre, 1978.
4. Les pièces peuvent être sujettes à des modifications sans préavis.

## Notas para usar este Libro de Piezas

1. De haber un símbolo  junto al "Parts No. (Número de Pieza)" o en la columna del "Assembly No. (Número de Juego)", habrá que mirar la lista de piezas separada de la página 18.
2. El símbolo , que se encuentra en la columna del "Número de Pieza", quiere decir que no se dispone de dicha pieza sola. Cuando, empero, hay un número en la columna del "Numero de Juego", se podrá ordenar la pieza con todo el juego. Por lo tanto, será mejor hacer el pedido recurriendo al número del juego respectivo.
3. Este libro ha sido compilado basándose en los datos de que se disponía en Noviembre de 1978.
4. Las piezas quedan sujetas a cambios de diseño sin aviso previo.

## CONTENTS

A. Machine Body and Threading .....	1
B. Upper Shaft, Thread Take-up and Rotary Hook Mechanism .....	2
C. Feed Mechanism (Part 1) .....	3
C. Feed Mechanism (Part 2) .....	4
D. Presser Foot and Knee Lifter Mechanism .....	5
E. Lubrication .....	6
F. Thread Trimmer and Tension Releaser .....	7
G. Synchronizer .....	8
H. Thread Wiper (-200, -400, -500) . Quick Back Switch Mechanism (-400, -500) .....	9
J. Quick Back Mechanism (-400, -500) .....	10
K. Presser Lifter Mechanism (-500) .....	11
L. Valve Box (-500) .....	12
M. Control Box .....	13
N. Motor (Part 1) .....	14
N. Motor (Part 2) .....	15
U. Bobbin Winder Mechanism .....	16
Z. Accessories .....	17
DIFFERENT PARTS LIST .....	18
INDEX .....	21



## A. Machine Body and Threading

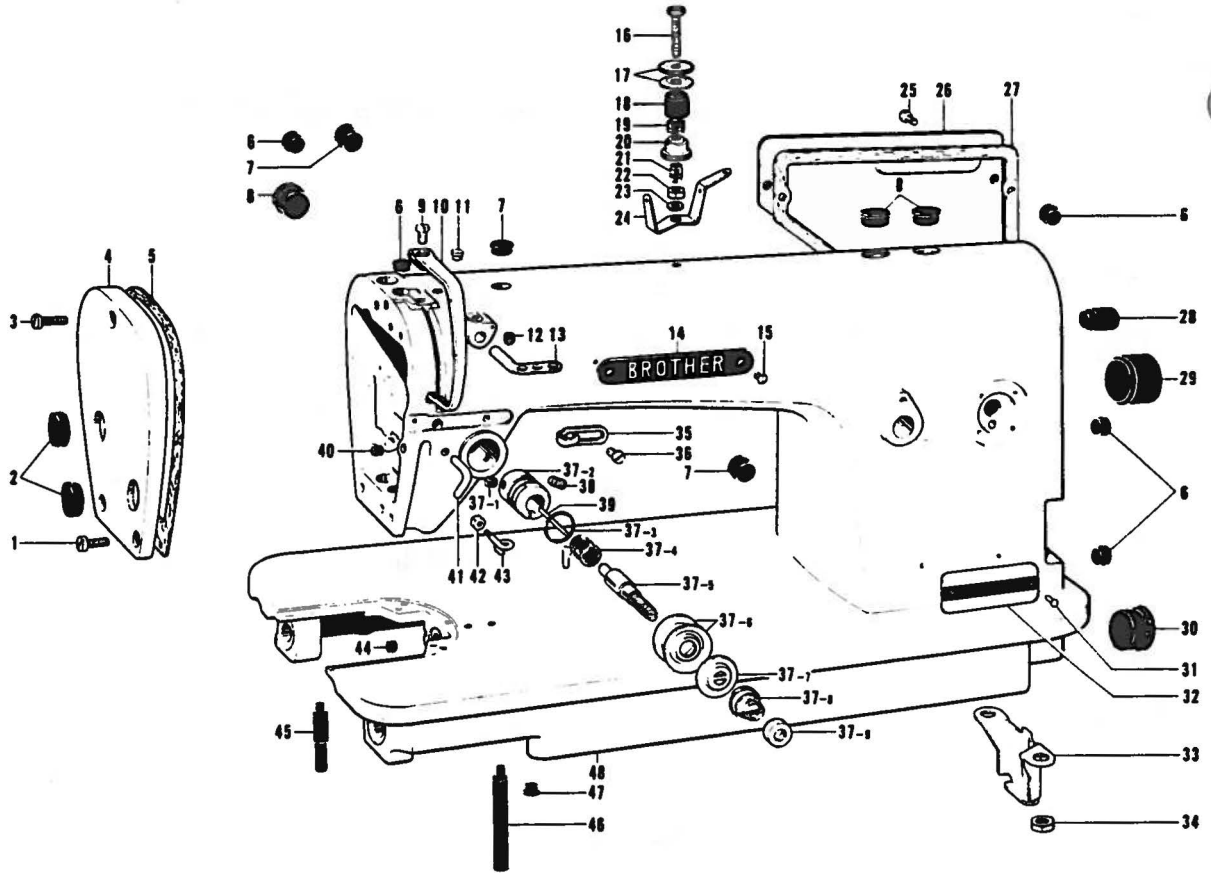

Ref. No.	Name of Parts	Q'ty	Parts No.	Assembly No.	Ref. No.	Name of Parts	Q'ty	Parts No.	Assembly No.
A-1	Screw	2	009671-0-13		A-29	Oil Cap	1	104451-0-01	
A-2	Oil Cap	2	104449-0-01		A-30	Oil Cap	1	108520-0-01	
A-3	Screw	1	009671-8-13		A-31	Model Plate Pin	2		
A-4	Face Plate	1			A-32	Model Plate	1		
A-5	Packing	1	145527-0-00		A-33	Pump Cover	1	145454-0-01	
A-6	Vinyl Cap	5	104450-0-01		A-34	Nut	2	100090-0-04	
A-7	Oil Cap	3	104821-0-01		A-35	Thread Guide	1	145522-0-01	
A-8	Oil Cap	3	104449-0-01		A-36	Screw	1	009670-6-14	
A-9	Screw	1	009680-7-13		A-37-1	Screw	1	100402-0-04	A-37 Tension Regulator Assembly
A-10	Thread Take-up Cover	1	140885-0-02		A-37-2	Upper Tension Regulator Bracket	1	144741-0-01	
A-11	Oil Cap	1	111865-0-01		A-37-3	Packing	1	114294-0-01	
A-12	Screw	1	151602-0-02		A-37-4	Thread Take-up Spring	1	145519-0-01	
A-13	Thread Retainer	1	114931-0-01		A-37-5	Tension Stud	1	100398-0-01	
A-14	Name Plate	1			A-37-6	Tension Disc	2	145446-0-01	
A-15	Screw	2			A-37-7	Tension Disc Washer	1	100134-0-01	
A-16	Pre-Tension Stud	1	146056-0-01		A-37-8	Tension Spring	1		
A-17	Thread Guide Disc	2	147705-0-01		A-37-9	Nut	1	100136-0-01	
A-18	Washer	1	146206-0-01		A-38	Screw	1	103950-0-02	
A-19	Spring	1	146058-0-01		A-39	Tension Release Pin	1	150551-0-00	
A-20	Nut	1	146059-0-01		A-40	Screw	1	011711-4-12	
A-21	Spring	1	146060-0-00		A-41	Thread Guide	1	116112-0-01	
A-22	Nut	1	105234-0-01		A-42	Nut	1	021660-1-02	
A-23	Washer	1	025680-2-34		A-43	Arm Thread Guide	1	145524-0-01	
A-24	Thread Guide Plate	1	146055-0-01		A-44	Cap	1	142274-0-01	
A-25	Screw	5	009670-8-12		A-45	Bed Leg B	1	104830-0-01	
A-26	Rear Cover	1	145455-0-01		A-46	Bed Leg A	1	104829-0-01	
A-27	Packing	1	145528-0-00		A-47	Oil Cap	1	104833-0-01	
A-28	Oil Cap	1	104832-0-01		A-48	Arm Bed	1		



## B. Upper Shaft, Thread Take-up and Rotary Hook Mechanism

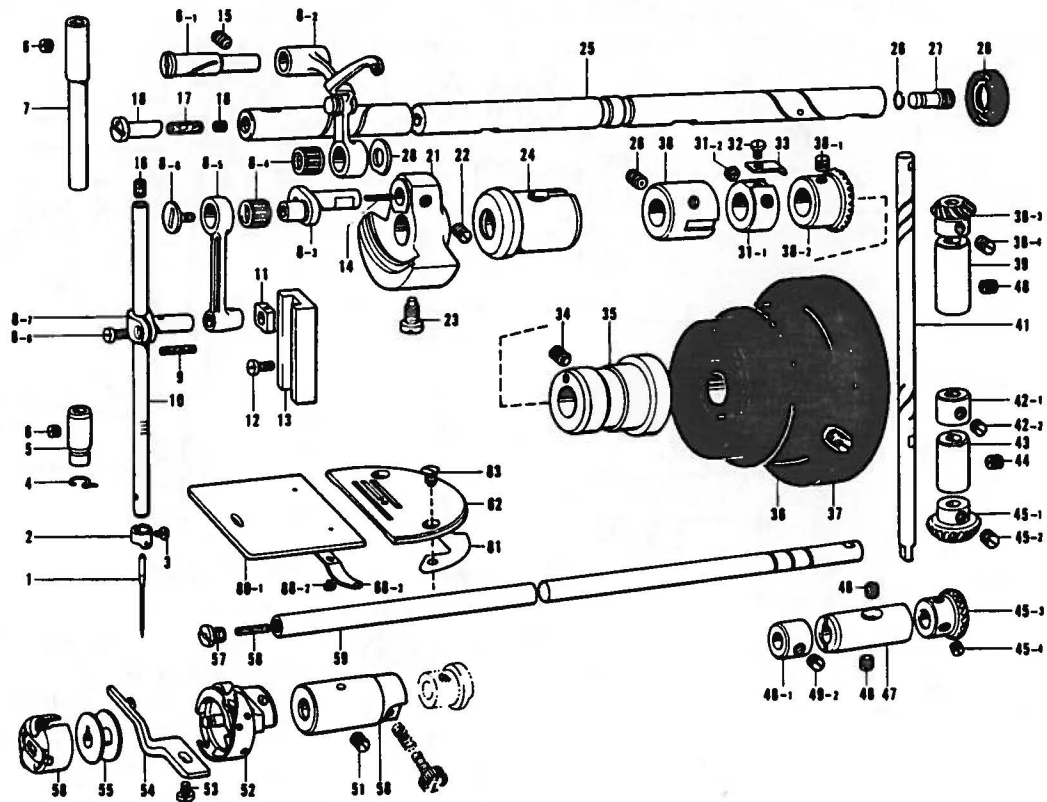

Ref. No.	Name of Parts	Q'ty	Parts No.	Assembly No.	Ref. No.	Name of Parts	Q'ty	Parts No.	Assembly No.
B-1	Needle	1			B-33	Feed Cam Stopper	1	147764-0-01	
B-2	Thread Guide	1	145944-0-01		B-34	Screw	1	013760-6-10	
B-3	Screw	1	140553-0-01		B-35	Upper Shaft Bushing Right	1	145461-1-01	
B-4	Thread Guide	1	145525-0-01		B-36	Pulley	1	148823-0-01	
B-5	Needle Bar Bushing	1			B-37	Screw	2	013761-4-10	
B-6	Screw	2	100260-0-01		B-38-1	Screw	2	151606-0-01	B-38 Bevel Gear Upper Assembly 140378-0-01
B-7	Needle Bar Bushing Upper	1	111463-0-01		B-38-2	Gear	1		
B-8-1	Stud	1		B-8 Thread Take-up Lever Assembly	B-38-3	Gear	1		
B-8-2	Thread Take-up Supporter Assembly	1			B-38-4	Screw	2	151606-0-01	
B-8-3	Needle Bar Crank	1			B-39	Vertical Shaft Upper Bushing	1	142708-0-00	
B-8-4	Needle Bearing	2			B-40	Screw	1	013760-6-10	
B-8-5	Needle Bar Crank Rod	1			B-41	Vertical Shaft	1	145516-0-01	
B-8-6	Screw	1	145465-0-01		B-42-1	Collar	1		B-42 Collar 181995-0-01
B-8-7	Needle Bar Clamp	1			B-42-2	Screw	2	101706-0-03	
B-8-8	Screw	1	140004-0-01		B-43	Vertical Shaft Lower Bushing	1	142709-0-00	
B-9	Wick	1	108809-0-01	B-44	Screw	1	013761-4-10		
B-10	Needle Bar	1		B-45-1	Gear	1		B-45 Bevel Gear Upper Assembly 140381-0-01	
B-11	Block for Needle Bar Guide	1		B-45-2	Screw	2	151606-0-01		
B-12	Screw	2	009670-6-12	B-45-3	Gear	1			
B-13	Needle Bar Guide	1	145688-0-00	B-45-4	Screw	2	151606-0-01		
B-14	Felt	1	145624-0-00	B-46	Felt	1	107155-0-01		
B-15	Screw	1	013781-0-12	B-47	Lower Shaft Bushing Right	1	104520-0-00		
B-16	Oil Adjuster	1	146333-0-01	B-48	Screw	1	151607-0-01		
B-17	Felt	1	146327-0-01	B-49-1	Collar	1		B-49 Collar 181995-0-01	
B-18	Wick	1	107149-0-01	B-49-2	Screw	2	101706-0-03		
B-19	Needle Bar Cork	1	111863-0-01	B-50	Lower Shaft Bushing Left	1	118761-0-00		
B-20	Washer	1	110367-0-01	B-51	Screw	1	151603-0-02		
B-21	Thread Take-up Crank	1	148965-0-00	B-52	Rotary Hook Assembly	1	153131-901		
B-22	Screw	2	151606-0-01	B-53	Screw	1	107407-0-03		
B-23	Screw	1	104464-0-01	B-54	Bobbin Case Holder Position Bracket	1			
B-24	Upper Shaft Bushing Left	1	145459-1-01	B-55	Bobbin	1	100376-0-01		
B-25	Upper Shaft	1	147511-0-01	B-56	Bobbin Case Assembly	1	148350-1-01		
B-26	O Ring	1	081002-6-70	B-57	Screw	1	109173-0-01		
B-27	Oil Screw Right for Upper Shaft	1	104555-0-01	B-58	Felt	1	145751-0-01		
B-28	Oil Seal	1	101487-0-00	B-59	Lower Shaft	1	145517-0-01		
B-29	Screw	1	151604-0-01	B-60-1	Slide Plate	1		B-60 Slide Plate Assembly 180018-0-01	
B-30	Upper Shaft Bushing Intermediate	1	140726-0-00	B-60-2	Screw	2	122771-0-01		
B-31-1	Set Collar	1		B-60-3	Slide Plate Spring	1	114561-0-01		
B-31-2	Screw	2	151606-0-01	B-61	Needle Plate Washer	1			
B-32	Screw	1	009670-4-12	B-62	Needle Plate	1			
				B-63	Screw	2	100032-0-03		

### C. Feed Mechanism(Part 1 )

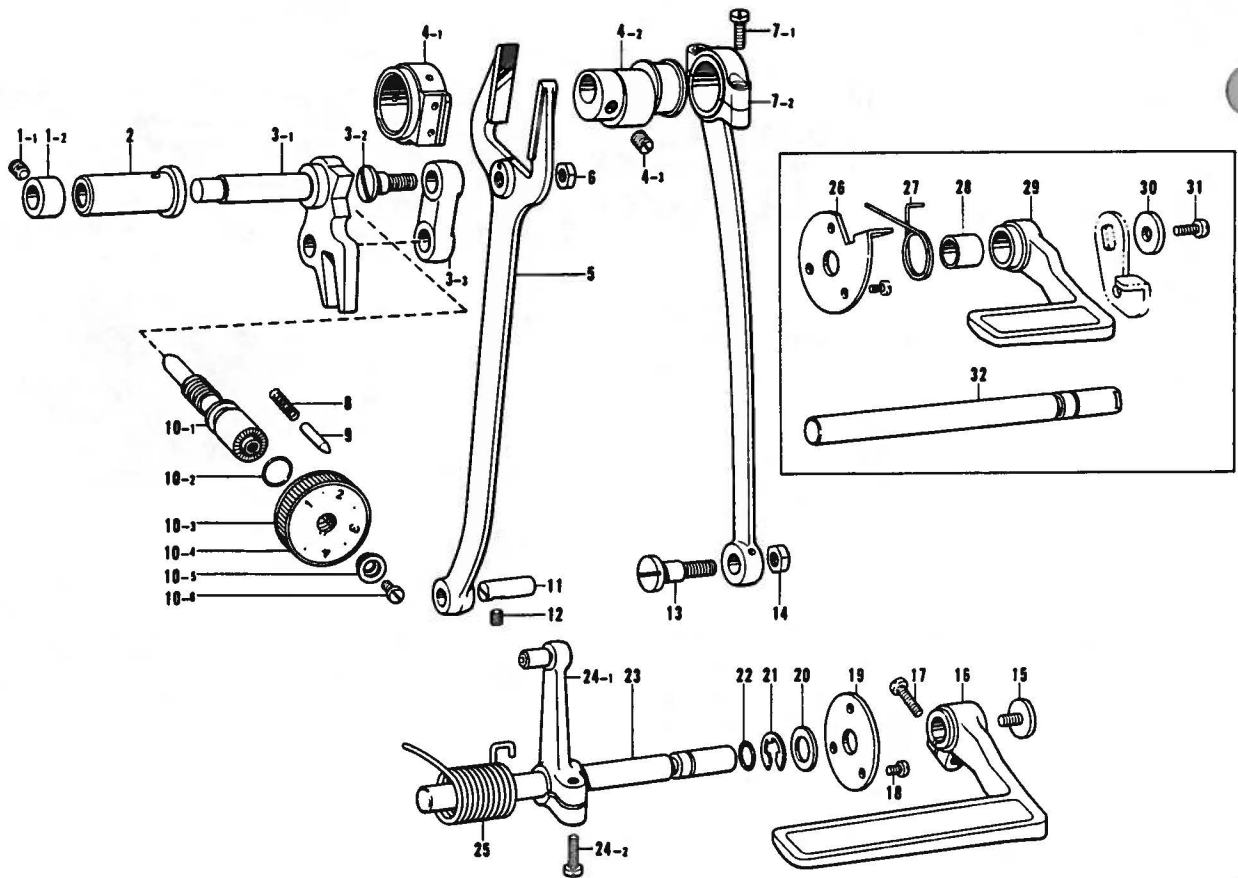

Ref. No.	Name of Parts	Q'ty	Parts No.	Assembly No.	Ref. No.	Name of Parts	Q'ty	Parts No.	Assembly No.
C- 1-1	Screw	1	100260-0-01	C-1 Set Collar Assembly 181934-0-01	C-12	Screw	1	151601-0-02	
C- 1-2	Set Collar	1			C-13	Stud Screw 7.14	1	147509-0-01	
C- 2	Feed Regulator Shaft Bushing	1	147500-0-00		C-14	Nut	1	104689-0-01	
C- 3-1	Feed Regulator	1		C-3 Feed Regulator Assembly 147628-0-01	C-15	Screw	1		
C- 3-2	Screw	1	145486-0-01		C-16	Reverse Lever	1		
C- 3-3	Feed Link	1	147502-0-00		C-17	Screw Lever Plate	1		
C- 4-1	Feed Cam Sleeve	1		C-4 Feed Cam Sleeve Assembly 147573-0-01	C-18	Screw	3	007670-5-13	
C- 4-2	Feed Cam	1			C-19	Reverse	1		
C- 4-3	Screw	2	151604-0-01		C-20	Washer	1	025100-1-32	
C- 5	Feed Forked Connector	1	109147-0-01		C-21	Stop Ring	1	048080-3-42	
C- 6	Nut	1	104689-0-01		C-22	Packing	1	104564-0-01	
C- 7-1	Screw	2	107428-0-01	C-7 Crank Rod Assembly 145506-0-01	C-23	Reverse Lever Shaft	1		
C- 7-2	Crank Rod	1			C-24-1	Lever Assembly	1		C-24 Feed Regulator Lever Assembly 181935-0-01
C- 8	Spring	1	100328-0-01		C-24-2	Screw	1	009711-4-12	
C- 9	Pin	1	145502-0-01		C-25	Spring	1		
C-10-1	Length Control Screw	1	109151-1-01		C-26	Reverse Lever Stopper	1		
C-10-2	Packing	1	108549-0-01		C-27	Reverse Lever Presser Spring	1		
C-10-3	Length Control Dial	1	151320-0-01	C-10 Length Control Assembly	C-28	Collar	1		
C-10-4	Length Control Plate	1			C-29	Reverse Lever	1		
C-10-5	Washer	1	142746-0-02		C-30	Washer	1		
C-10-6	Screw	1	142747-0-02		C-31	Screw	1		
C-11	Feed Rock Shaft Arm Pin	1	109153-0-01		C-32	Reverse Lever Shaft	1		

### C. Feed Mechanism(Part 2 )

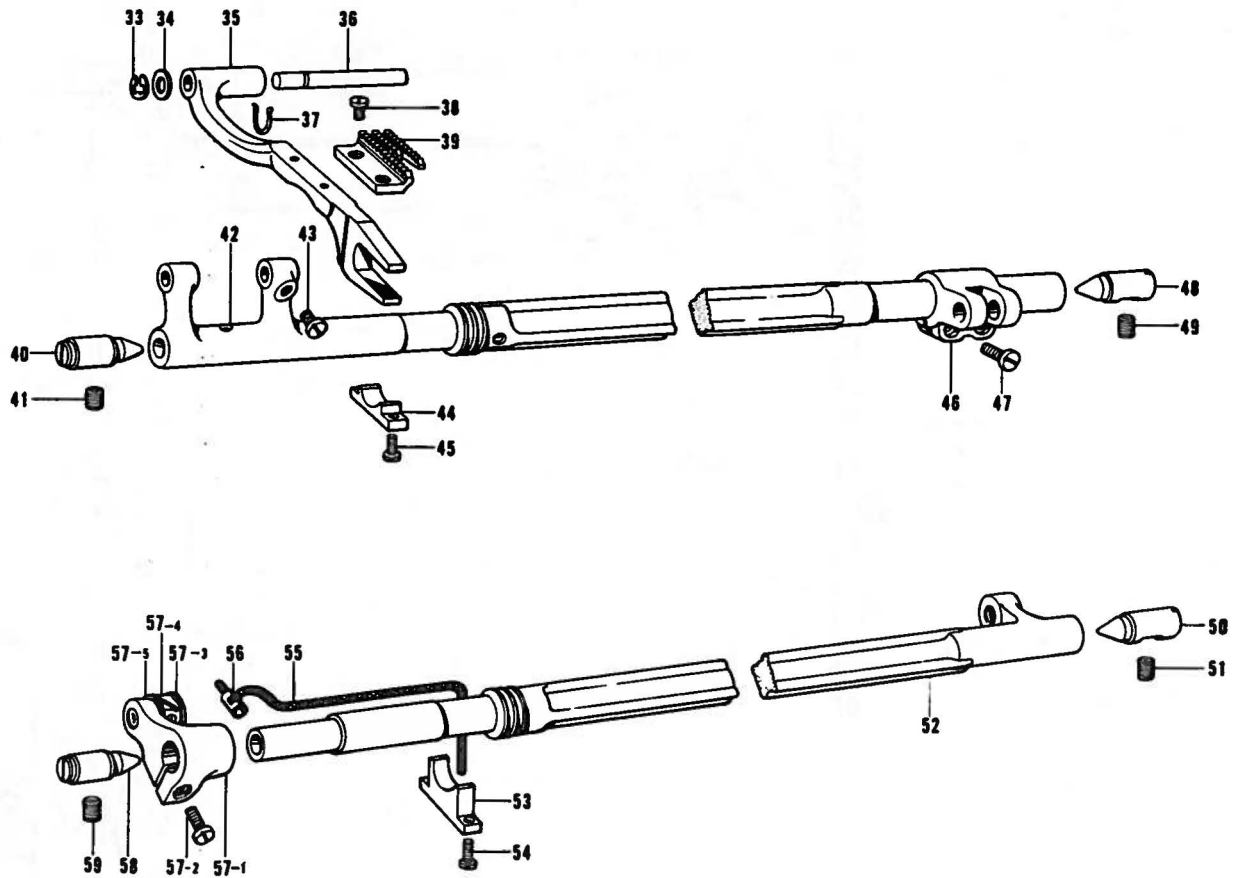

Ref. No.	Name of Parts	Q'ty	Parts No.	Assembly No.	Ref. No.	Name of Parts	Q'ty	Parts No.	Assembly No.
C-33	Stop Ring	1	048080-3-42		C-49	Screw	1	151606-0-01	
C-34	Ring	1	115663-0-01		C-50	Taper Center Right	1	104848-0-01	
C-35	Feed Bar	1	147767-0-01		C-51	Screw	1	151606-0-01	
C-36	Feed Bar Shaft	1	147508-0-01		C-52	Feed Lifting Shaft	1	147510-0-01	
C-37	Wick Hanger	1	150342-0-01		C-53	Oil Stopper	1	118559-0-01	
C-38	Screw	2	100080-0-03		C-54	Screw	2	009670-8-12	
C-39	Feed Dog	1			C-55	Wick	1	108802-0-01	
C-40	Taper Center Left	1	104847-0-01		C-56	Wick Supporter	1	104567-0-01	
C-41	Screw	1	151606-0-01		C-57-1	Feed Lifting Arm	1		
C-42	Feed Rock Shaft	1	147506-0-01		C-57-2	Screw	1	009681-6-12	C-57
C-43	Screw	1	104908-0-01		C-57-3	Slide Block Stud	1		Feed Lifting
C-44	Oil Stopper	1	118558-0-01		C-57-4	Slide Block	1		Arm Assembly
C-45	Screw	2	009670-8-12		C-57-5	Washer	1		181941-0-01
C-46	Feed Rock Shaft Arm	1	109152-0-01		C-58	Taper Center Left	1	104847-0-01	
C-47	Screw	2	009681-2-12		C-59	Screw	1	151606-0-01	
C-48	Taper Center Right	1	104848-0-01						



## D. Presser Foot and Knee Lifter Mechanism

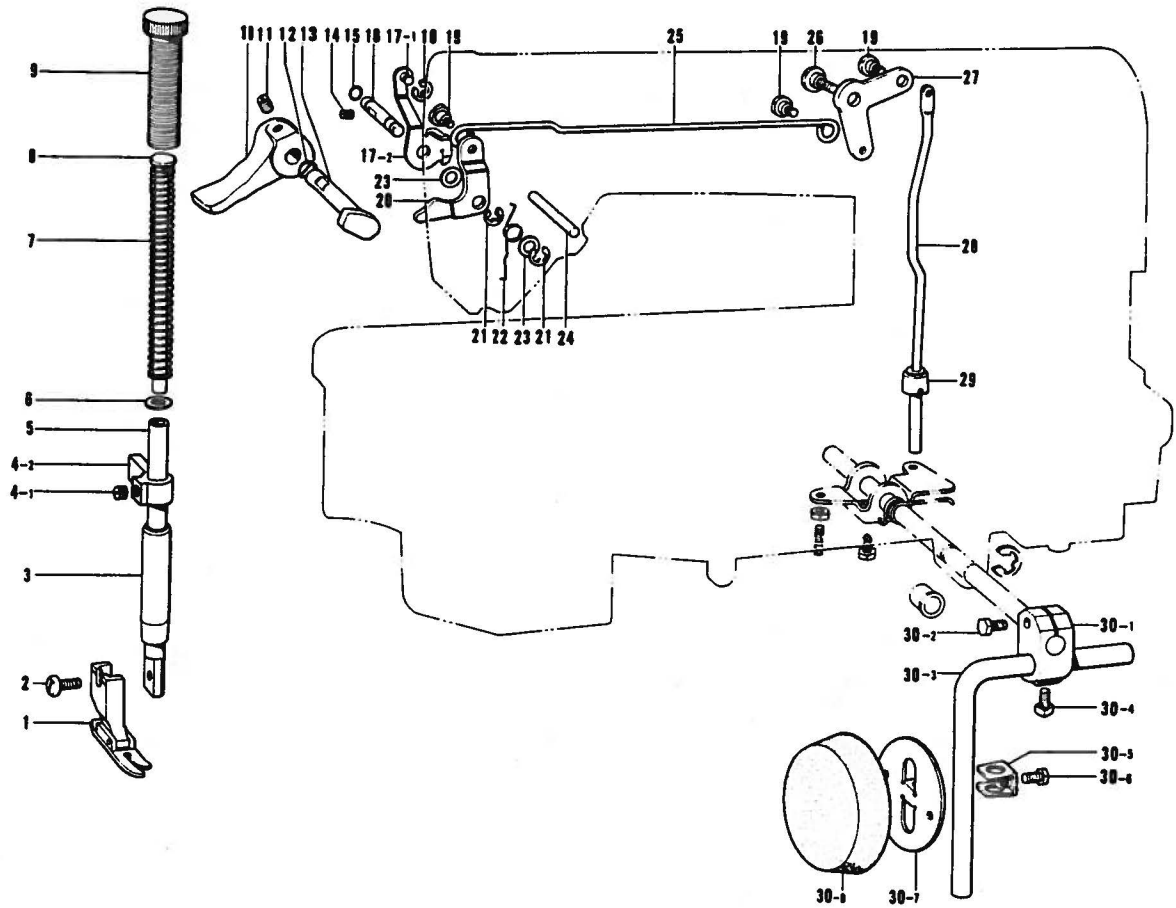

Ref. No.	Name of Parts	Q'ty	Parts No.	Assembly No.	Ref. No.	Name of Parts	Q'ty	Parts No.	Assembly No.
D-1	Presser Foot	1			D-19	Screw	3	145478-0-01	
D-2	Screw	1	001671-0-14		D-20	Presser Bar Lifter Lever Shaft	1	145580-0-01	
D-3	Presser Bar Bushing	1	145472-0-01		D-21	Stop Ring	2	048040-3-42	
D-4-1	Presser Bar Clamp	1			D-22	Spring	1		
D-4-2	Screw	1	013760-6-10	D-4 Presser Bar Clamp Assembly 181919-0-01	D-23	Washer	2	109763-0-02	
D-5	Presser Bar	1	111466-0-01		D-24	Tension Release Stud	1	145691-0-01	
D-6	Presser Spring Washer	1	140407-0-01		D-25	Knee Lifter Connector	1	145476-0-01	
D-7	Presser Spring	1	147514-0-01		D-26	Screw	1	145480-0-01	
D-8	Presser Spring Bar	1	141208-0-01		D-27	Knee Lifter Lever	1	145479-0-01	
D-9	Screw	1	141207-0-01		D-28	Knee Lifter Bar	1	145481-0-01	
D-10	Presser Bar Lifter	1	145482-0-01		D-29	Knee Lifter Complying Bar	1	145573-0-00	
D-11	Screw	1	013710-5-12		D-30-1	Knee Lifter Joint	1	146039-0-01	
D-12	Packing	1	081001-6-70		D-30-2	Bolt	1	017762-0-13	
D-13	Presser Bar Lifter Crank	1	145483-0-01		D-30-3	Knee Lifter Bar	1	104619-0-02	
D-14	Screw	1	100128-0-02		D-30-4	Bolt	1	100463-0-01	
D-15	O Ring	1	081003-0-70		D-30-5	Knee Lifter Plate Stopper	1	114967-0-01	
D-16	Presser Bar Lifter Lever Shaft	1	145474-0-01		D-30-6	Bolt	1	110087-0-01	
D-17-1	Tension Release Bar Hook	1			D-30-7	Knee Lifter Plate	1	114966-0-01	
D-17-2	Tension Release Plate	1		D-17 Tension Releaser	D-30-8	Knee Lifter Cover	1	140503-0-01	
D-18	Stop Ring	1	048030-3-42						D-30 Knee Lifter Assembly

## E. Lubrication

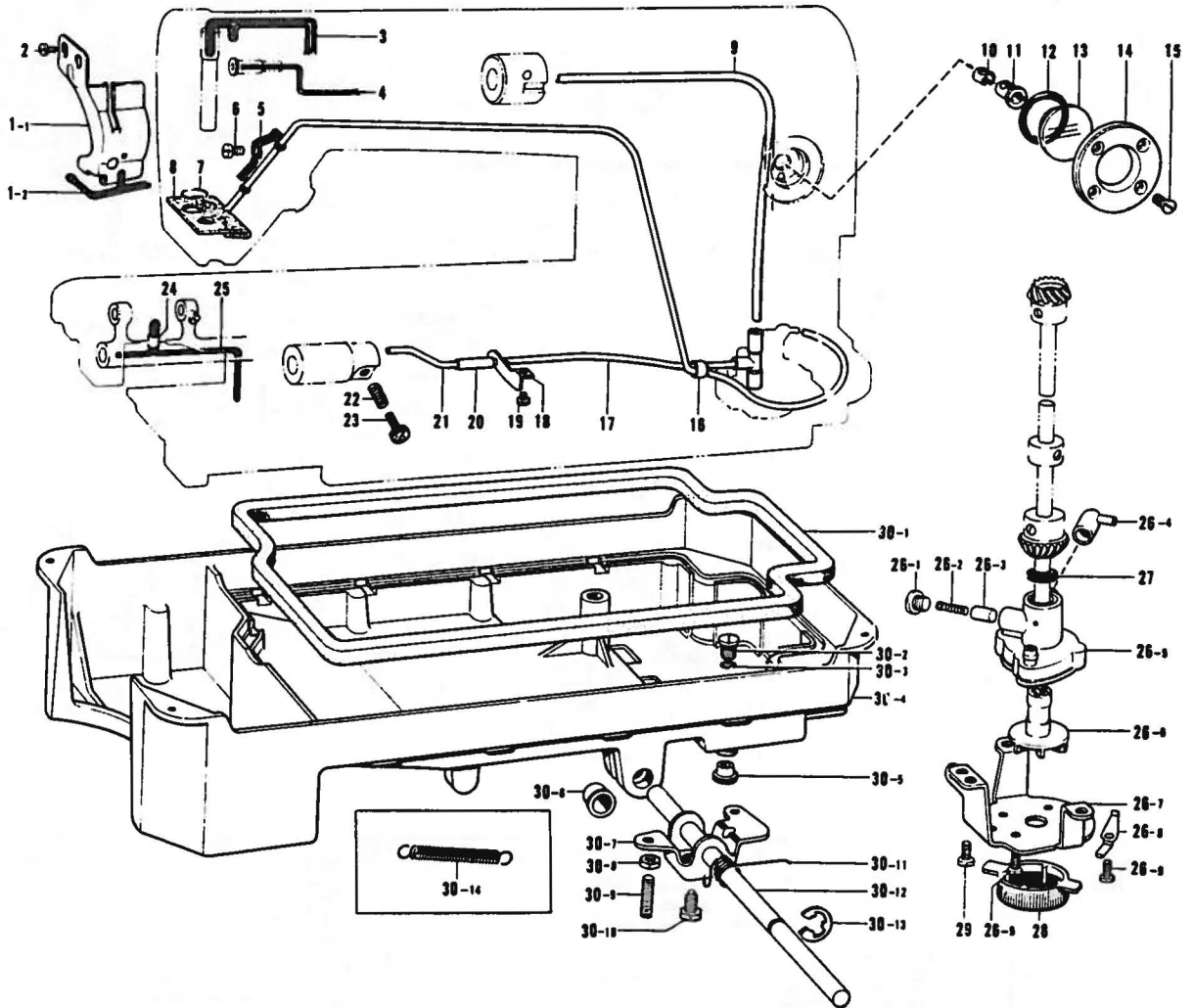

Ref. No.	Name of Parts	Q'ty	Parts No.	Assembly No.	Ref. No.	Name of Parts	Q'ty	Parts No.	Assembly No.
E- 1-1	Oil Stopper Plate	1		E-1 Oil Stopper Plate Assembly 181639-0-01	E-26-1	Oil Draining Screw	1	112467-0-02	E-26 Pump Body Assembly 181476-1-01
E- 1-2	Wick	1	109405-0-01		E-26-2	Spring	1	144876-0-01	
E- 2	Screw	2	009670-5-12	E-26-3	Plunger	1	144875-0-01		
E- 3	Wick	1	108804-0-01	E-26-4	Joint	1	144878-0-01		
E- 4	Wick	1	109405-0-01	E-26-5	Pump Body	1	148848-0-01		
E- 5	Tube Holder	1	145547-0-01	E-26-6	Pump Propeller	1	148849-0-01		
E- 6	Screw	1	009670-5-13	E-26-7	Pump	1	144869-0-01		
E- 7	Felt Support	1	145737-0-01	E-26-8	Spring	2	144874-0-01		
E- 8	Tube	1	145543-0-01	E-26-9	Screw	4	009670-8-12		
E- 9	Oil Tube Upper	1	147496-0-00	E-27	Oil Stopper	1	146196-0-01		
E-10	Tube Holder Cap	1	146314-0-00	E-28	Pump Filter	1	144872-0-01		
E-11	Tube Holder	1	145529-0-00	E-29	Screw	3	009680-7-13		
E-12	O Ring	1	081014-6-70	E-30-1	Packing	1	146040-0-01		
E-13	Oil Gauge Window	1	104547-0-01	E-30-2	Screw	1	140518-0-01		
E-14	Oil Gauge Flange	1	104546-0-01	E-30-3	O Ring	1	081007-0-70		
E-15	Screw	1	102538-0-02	E-30-4	Oil Pan	1			
E-16	Tube	1	146253-0-00	E-30-5	Oil Cap	1	140480-0-01		
E-17	Oil Tube D Assembly	1	149144-0-01	E-30-6	Knee Lifter Shaft Bushing	2	149578-0-00		
E-18	Tube Holder	1	149146-0-01	E-30-7	Knee Lifter	1	146037-0-01		
E-19	Screw	1	009680-6-12	E-30-8	Nut	2	100022-0-04		
E-20	Tube Joint	1	149998-0-00	E-30-9	Screw	2	104885-0-01		
E-21	Oil Tube Lower	1	149999-0-00	E-30-10	Bolt	1	146367-0-01		
E-22	Spring	1	116794-0-01	E-30-11	Spring	1			
E-23	Screw	1	145534-0-01	E-30-12	Knee Lifter Shaft	1			
E-24	Vinyl Tube	1	150340-0-00	E-30-13	Stop Ring	1	146293-0-01		
E-25	Wick	1	108801-0-01	E-30-14	Spring	2			



## F. Thread Trimmer and Tension Releaser

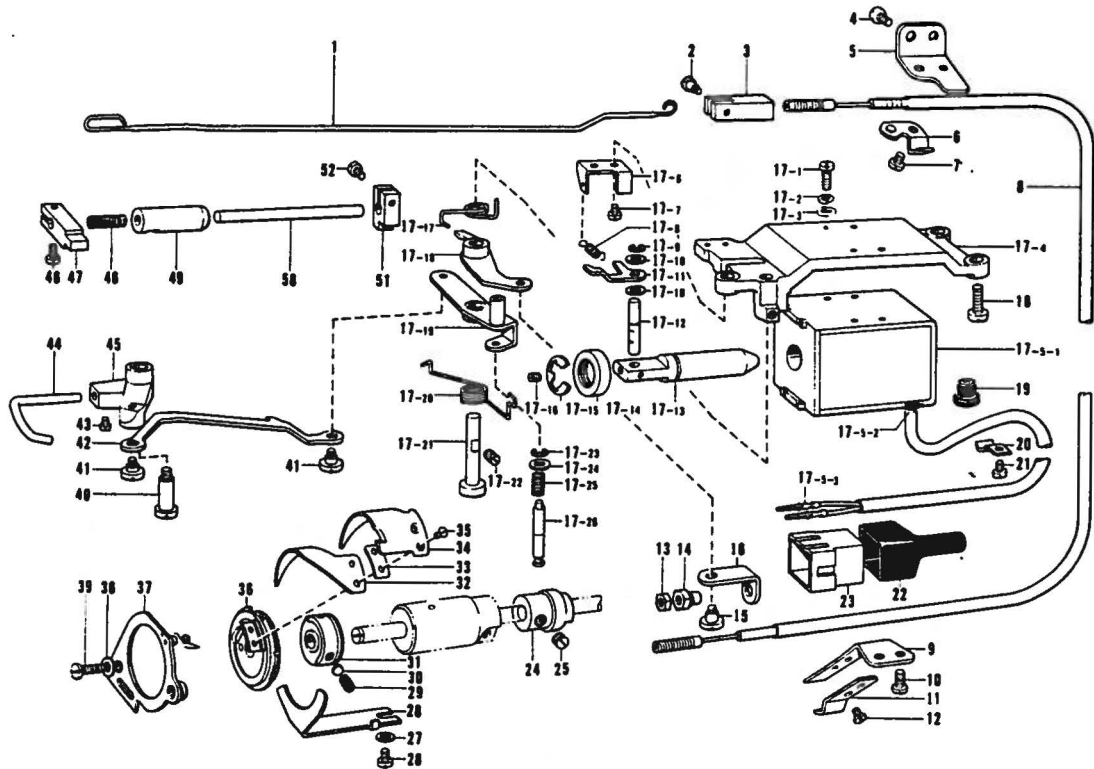

Ref. No.	Name of Parts	Q'ty	Parts No.	Assembly No.	Ref. No.	Name of Parts	Q'ty	Parts No.	Assembly No.
F- 1	Tension Release Bar	1	149138-0-01		F-17-23	Stop Ring	1	048030-3-42	F-17 Solenoid Bracket Assembly
F- 2	Stud Screw	1	149137-0-01		F-17-24	Washer	1	025040-2-32	
F- 3	Tension Release Wire Joint	1	149136-0-01		F-17-25	Lever Stud Spring	1	150352-0-00	
F- 4	Screw	2	009670-6-12		F-17-26	Bobbin Finger Lever Stud	1	149724-0-01	
F- 5	Tension Release Wire Holder U	1	149134-0-01		F-18	Screw	3	009781-4-12	
F- 6	Tension Release Wire Presser U	1	149135-1-01		F-19	Bushing	1	146080-0-00	
F- 7	Screw	1	001670-6-12		F-20	Supporter	1	140647-0-01	
F- 8	Tension Release Wire	1	149130-1-01		F-21	Screw	1	009670-6-12	
F- 9	Tension Release Wire Holder D	1	149132-0-01		F-22	Connector Cap	1		
F-10	Screw	2	009680-6-12		F-23	Nylon Connector	1		
F-11	Tension Release Wire Presser D	1	149133-1-01		F-24	Bobbin Finger Driving Cam	1	149725-0-01	
F-12	Screw	1	001670-6-12		F-25	Screw	2	101706-0-01	
F-13	Nut	1	021670-2-03		F-26	Screw	1	009680-7-13	
F-14	Wire Sleeve	1	149775-0-01		F-27	Washer	1	025680-1-33	
F-15	Stud Screw	1	149127-0-01		F-28	Cover	1	149128-0-01	
F-16	Tension Release Link	1	149131-0-01		F-29	Screw	3	014680-6-22	
F-17- 1	Screw	4	007401-0-12	F-17-5 Thread Trimming Solenoid Assembly	F-30	Washer	3	147697-0-01	
F-17- 2	Washer	4	028040-2-43		F-31	Thread Trimmer Clutch	1	149709-0-01	
F-17- 3	Washer	4	025040-1-33		F-32	Lower Thread Finger	1	145610-1-01	
F-17- 4	Thread Trimming Solenoid Bracket	1	149110-0-01		F-33	Spacer	1		
F-17-5-1	Thread Trimming Solenoid	1			F-34	Movable Knife	1	145608-0-01	
F-17-5-2	Bushing	1			F-35	Screw	2	141542-0-01	
F-17-5-3	Terminal Pin	2			F-36	Movable Knife Holder Assembly	1	149710-0-01	
F-17- 6	Thread Trimming Claw Stopper	1	149120-0-01		F-37	Movable Knife Holder Plate Assembly	1	149712-0-01	
F-17- 7	Screw	2	100242-0-03		F-38	Washer	2	100645-0-03	
F-17- 8	Thread Trimming Claw Spring	1	149121-0-01		F-39	Screw	2	009681-2-12	
F-17- 9	Stop Ring	1	048030-3-40		F-40	Bobbin Finger Crank Stud	1	149124-0-01	
F-17-10	Washer	2	100645-0-03		F-41	Stud Screw	2	149127-0-01	
F-17-11	Thread Trimming Claw	1	149114-0-01		F-42	Bobbin Finger Connecting Rod	1	149726-0-01	
F-17-12	Plunger Pin	1	149113-0-01		F-43	Screw	2	144458-0-01	
F-17-13	Plunger	1	149111-0-01		F-44	Bobbin Finger	1	149125-0-01	
F-17-14	Plunger Stopper	1	149112-0-01		F-45	Bobbin Finger Crank	1	149123-0-01	
F-17-15	Stop Ring	1	048090-3-42		F-46	Screw	1	009660-7-12	
F-17-16	Screw	1	013679-4-12		F-47	Stopper	1	145617-0-01	
F-17-17	Thread Trimming Lever Spring	1	149115-0-01		F-48	Spring	1	145621-0-01	
F-17-18	Thread Trimming Lever	1	149722-0-01		F-49	Thread Trimming Shaft Bushing	1	149105-0-00	
F-17-19	Bobbin Finger Lever	1	149723-0-01		F-50	Thread Trimming Shaft	1	149104-0-01	
F-17-20	Bobbin Finger Lever Spring	1	149118-0-01		F-51	Thread Trimming Claw Block	1	149106-0-01	
F-17-21	Thread Trimming Lever Stud	1	149119-0-01	F-52	Screw	1	009660-7-12		
F-17-22	Screw	1	151602-0-02						



## G. Synchronizer

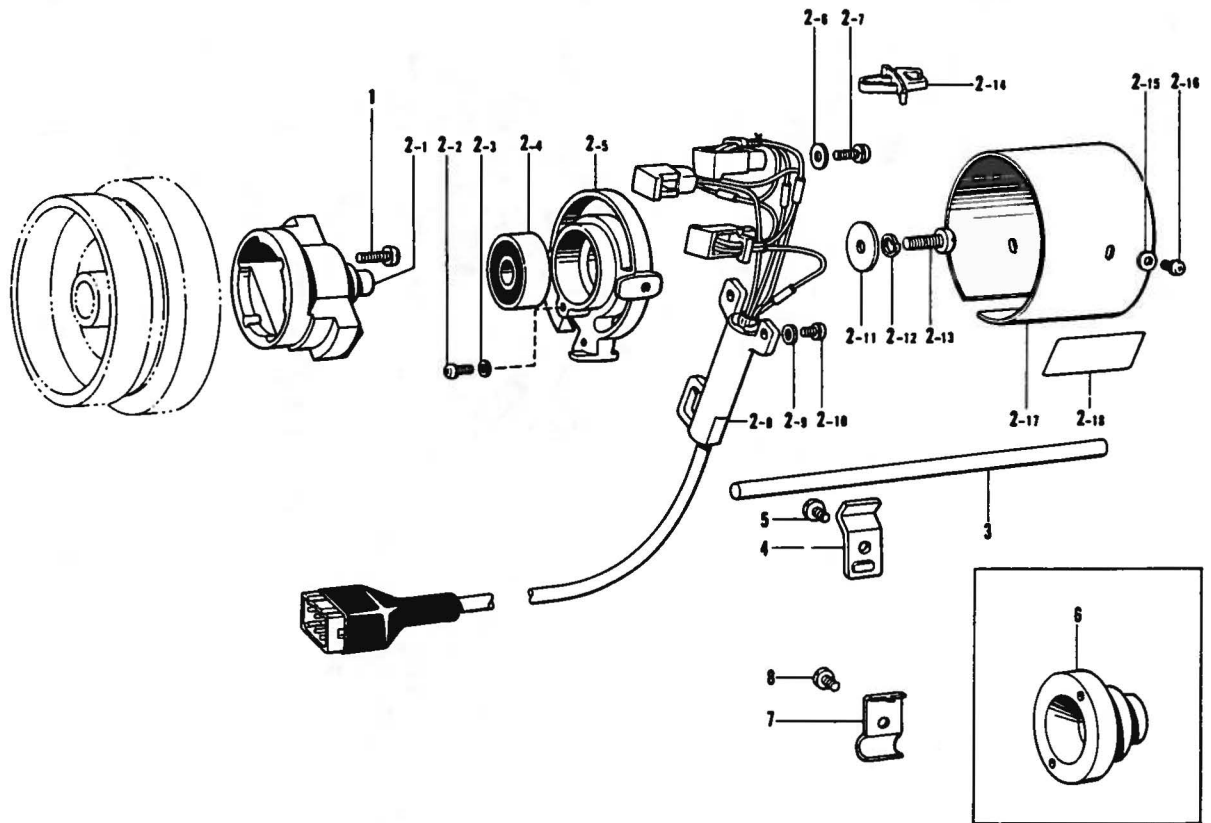

Ref. No.	Name of Parts	Q'ty	Parts No.	Assembly No.	Ref. No.	Name of Parts	Q'ty	Parts No.	Assembly No.
G-1	Screw	2	009711-4-12		G-2-13	Screw	1	216880-0-01	G-2 Synchronizer Assembly
G-2-1	Magnet Stud	1			G-2-14	Cord Holder	1		
G-2-2	Screw	1	215083-0-01		G-2-15	Washer	2	025040-1-35	
G-2-3	Washer	1	025030-3-35		G-2-16	Screw	2	215080-0-01	
G-2-4	Bearing	1			G-2-17	Synchronizer Cover	1		
G-2-5	Hole IC Holder	1			G-2-18	Level	1		
G-2-6	Washer	3	025040-3-35	G-2 Synchronizer Assembly	G-3	Synchronizer Holder Bar	1	218944-0-01	
G-2-7	Screw	3	217093-0-01		G-4	Holder	1	216332-0-01	
G-2-8	Hole IC with Cord	1	218953-0-01		G-5	Screw	1	009781-4-12	
G-2-9	Washer	2	025040-1-35		G-6	Slip Ring Support	1		
G-2-10	Screw	2	215080-0-01		G-7	Cord Stopper	1	145597-0-01	
G-2-11	Washer	1	025060-3-35		G-8	Screw	1	009680-5-12	
G-2-12	Washer	1	028060-2-34						

## H. Thread Wiper (-200, -400, -500)·Quick Back Switch Mechanism (-400, -500)

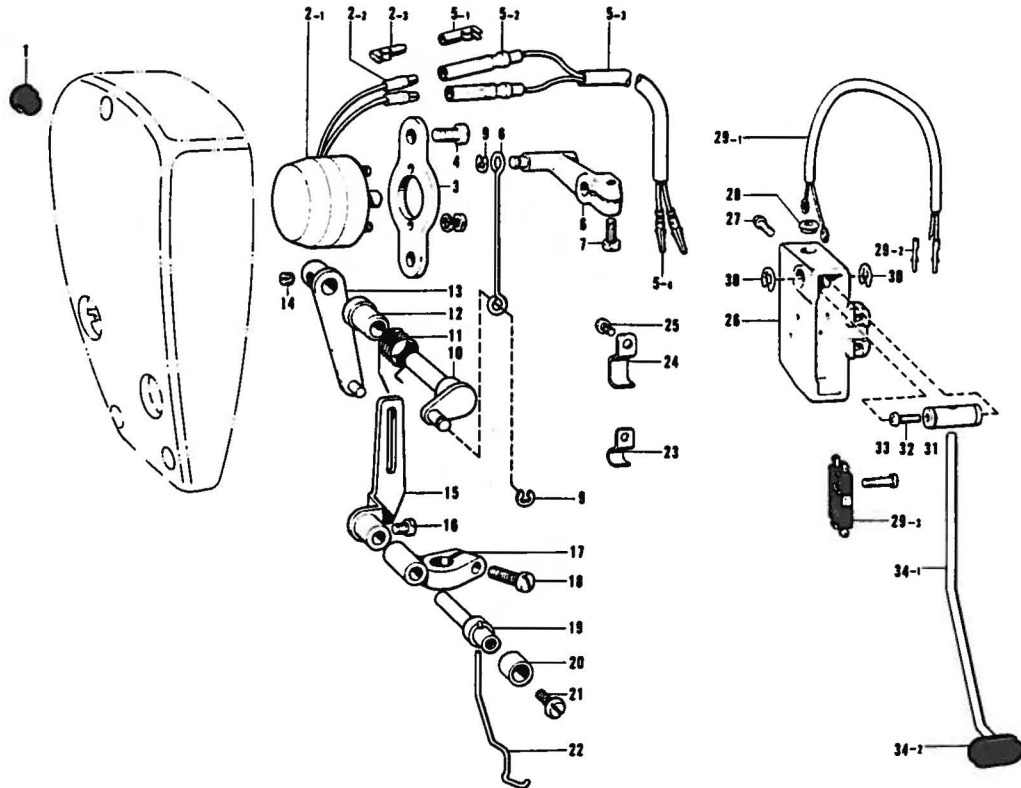

Ref. No.	Name of Parts	Q'ty	Parts No.	Assembly No.	Ref. No.	Name of Parts	Q'ty	Parts No.	Assembly No.
H- 1	Bushing	1	146080-0-00		H-17	Thread Wiper Supporter	1	146093-0-01	
H- 2-1	Rotary Solenoid	1		H-2 Thread Wiper Solenoid 146082-0-00	H-18	Screw	1	009681-4-14	
H- 2-2	Insulated Cover	2			H-19	Thread Wiper Stud	1	146092-0-01	
H- 2-3	Plug	2	146084-0-00		H-20	Thread Wiper Stud Collar	1	146288-0-01	
H- 3	Solenoid Set Plate	1	146081-0-01		H-21	Screw	1	001670-5-14	
H- 4	Screw	2	009680-8-12		H-22	Thread Wiper	1	146094-0-01	
H- 5-1	Insulated Sleeve	2		H-5 Cord	H-23	Supporter	3		
H- 5-2	Receptacle	2	146097-0-00		H-24	Tube Holder	3		
H- 5-3	Thread Wiper Cord	1			H-25	Screw	3	009670-6-12	
H- 5-4	Terminal Pin	2			H-26	Reverse Switch Case	1	146120-0-01	
H- 6	Solenoid Link	1	146086-0-01		H-27	Screw	2	009671-0-12	
H- 7	Screw	1	009671-0-13		H-28	Bushing	1	146080-0-00	
H- 8	Wire Link	1	146087-0-01		H-29-1	Reverse Switch Cord	1		H-29 Switch
H- 9	Stop Ring	2	048025-3-42		H-29-2	Terminal Pin	2		
H-10	Thread Wiper Crank	1	146088-0-01		H-29-3	Micro Switch	1	140643-0-00	
H-11	Spring	1	146089-0-01		H-30	Stop Ring	2	048080-3-42	
H-12	Bushing	1	146079-0-01		H-31	Actuator Pin	1	146125-0-01	
H-13	Thread Wiper Lever	1	146090-0-01		H-32	Screw	1	009681-4-14	
H-14	Screw	2	102716-0-02		H-33	Screw	2	146124-0-01	
H-15	Grooved Link	1	146091-0-01		H-34-1	Actuator	1	146127-0-01	H-34 Reverse Finger 146124-0-01
H-16	Screw	1	111443-0-01		H-34-2	Actuator	1	146128-0-00	

\* Parts of H-1~H-25 are Thread Wiper (-200, -400, -500).

\* Parts of H-26~H-34 are Quick Back Switch Mechanism (-400, -500).

# J. Quick Back Mechanism (-400, -500)

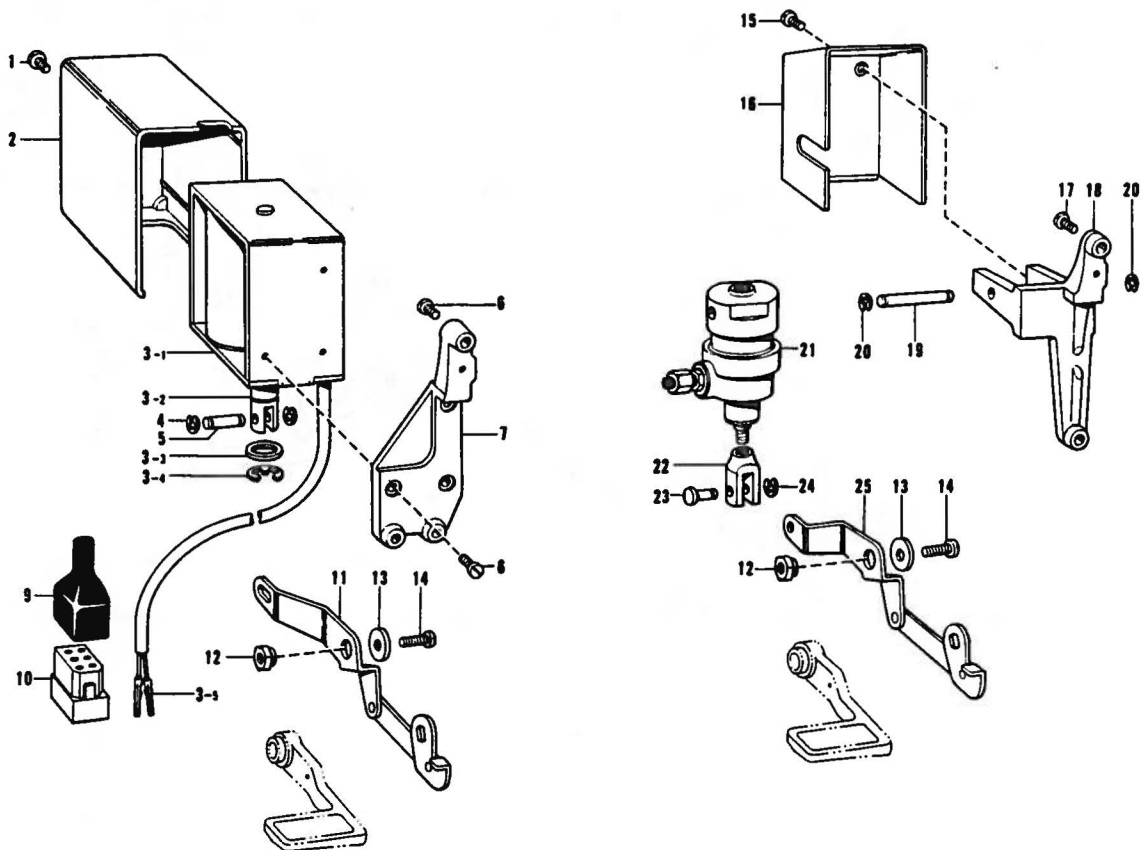

Ref. No.	Name of Parts	Q'ty	Parts No.	Assembly No.	Ref. No.	Name of Parts	Q'ty	Parts No.	Assembly No.
J- 1	Screw	1	007500-6-02	J-3 Reverse Solenoid	J-12	Solenoid Lever Stud	1	149094-0-01	
J- 2	Solenoid Cover	1	146105-0-00		J-13	Washer	1	149095-0-01	
J- 3-1	Solenoid	1			J-14	Screw	1	009781-4-12	
J- 3-2	Plunger	1			J-15	Screw	2	009670-5-13	
J- 3-3	Rubber Stopper	1	146104-0-00		J-16	Cover	1	146156-0-01	
J- 3-4	Stop Ring	1	146103-0-01		J-17	Screw	2	009781-8-12	
J- 3-5	Terminal Pin	2			J-18	Cylinder Supporter	1	149573-1-01	
J- 4	Stop Ring	2	048040-3-42		J-19	Cylinder Supporter Shaft	1	146148-0-01	
J- 5	Pin	1	147754-0-01		J-20	Stop Ring	2	048040-3-42	
J- 6	Screw	3	009781-8-12		J-21	Reverse Cylinder	1	146149-0-01	
J- 7	Reverse Solenoid Bracket	1	149140-1-01		J-22	Piston Rod Joint	1	140627-0-01	
J- 8	Screw	3	007500-8-12	J-23	Pin	1	146153-0-01		
J- 9	Connector Cap	1		J-24	Stop Ring	1	048040-3-42		
J-10	6P Connector	1		J-25	Reverse Cylinder Lever Assembly	1	149571-0-01		
J-11	Solenoid Lever Assembly	1	149089-0-01						

\* Parts J-1~J-14 are for -400 type specifications, and parts J-12~J-25 are for -500 type specifications.



# K. Presser Lifter Mechanism (-500)

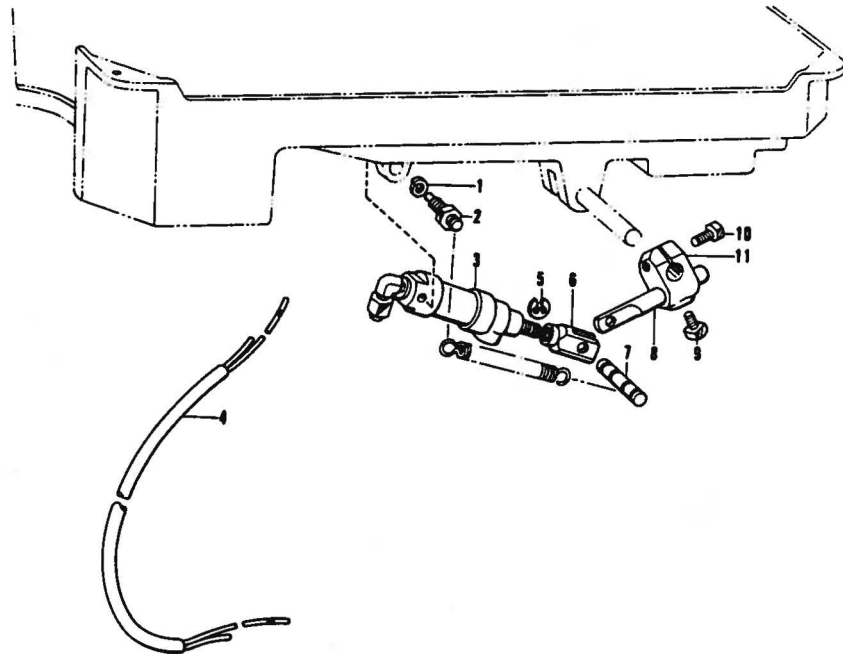

Ref. No.	Name of Parts	Q'ty	Parts No.	Assembly No.	Ref. No.	Name of Parts	Q'ty	Parts No.	Assembly No.
K- 1	Washer	2	028060-2-40		K- 7	Pin	1	146986-0-01	
K- 2	Screw	2	147141-0-01		K- 8	Piston Drive Link	1	140668-0-01	
K- 3	Presser Foot Cylinder	1	146157-0-01		K- 9	Bolt	1	100463-0-01	
K- 4	Air Tube Assembly	1	149548-0-01		K-10	Bolt	1	017762-0-13	
K- 5	Stop Ring	2	048040-3-42		K-11	Knee Lifter Joint	1	146039-0-01	
K- 6	Piston Rod Joint	1	140627-0-01						

# L. Valve Box (-500)

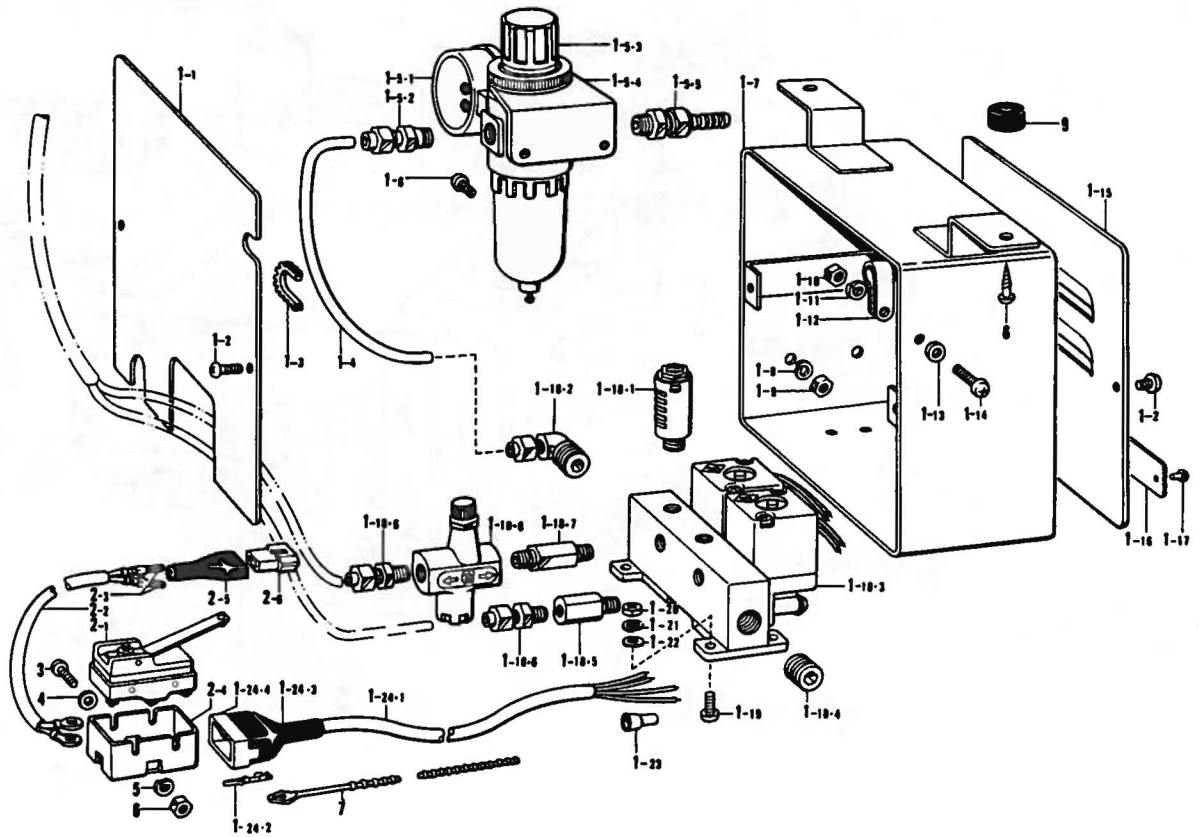

Ref. No.	Name of Parts	Q'ty	Parts No.	Assembly No.	Ref. No.	Name of Parts	Q'ty	Parts No.	Assembly No.
L-1-1	Back Cover	1			L-1-18-6	1/8" Connector	2	140543-0-00	L-1-18 Solenoid Valve Assembly
L-1-2	Screw	4	008400-5-64		L-1-18-7	Speed Control Connector	1	142037-0-00	149543-0-01
L-1-3	Nylon Bushing	1	146171-0-00		L-1-18-8	Speed Controller	1	142038-0-01	
L-1-4	Air Tube	1	140540-0-00		L-1-19	Screw	4	002401-2-03	
L-1-5-1	Presser Gauge	1		L-1-5 Air Unit Assembly 143959-1-03	L-1-20	Nut	4	021400-1-03	
L-1-5-2	Connector	1	142349-0-00		L-1-21	Washer	4	028040-2-43	
L-1-5-3	Plastic Bottol	1	143960-1-01		L-1-22	Washer	4	025040-1-33	
L-1-5-4	Air Unit Holder Plate	1	143962-0-01		L-1-23	Connector	4	206755-0-00	
L-1-5-5	Air Tube Connector	1	140678-0-00		L-1-24-1	Valve Cord	1		L-1-24 Valve Cord Assembly 149545-0-01
L-1-6	Screw	2	002501-0-64		L-1-24-2	Terminal Pin	4	143549-0-00	
L-1-7	Valve Case	1			L-1-24-3	Connector Cap	1	145596-0-01	
L-1-8	Washer	2	028050-2-43		L-1-24-4	6P Connector	1	146118-0-00	
L-1-9	Nut	2	021500-1-63		L-2-1	Micro Switch	1	140948-0-01	L-2 Presser Foot Lifter Cord Assembly
L-1-10	Nut	1	021300-1-03	L-1 Air Control Box	L-2-2	Presser Foot Lifter Cord	1		
L-1-11	Washer	1	028030-2-43		L-2-3	Terminal Pin	2	143549-0-00	
L-1-12	Cord Holder	1	149547-0-00		L-2-4	Cover	1	140950-0-00	
L-1-13	Washer	1	025030-1-33		L-2-5	Connector Cap	1	143489-0-01	
L-1-14	Screw	1	002301-0-03		L-2-6	Nylon Connector	1	143488-0-01	
L-1-15	Rear Cover	1			L-3	Screw	2		
L-1-16	Name Plate	1			L-4	Washer	2		
L-1-17	Rivet	2			L-5	Washer	2		
L-1-18-1	Silencer	2	140682-0-01		L-6	Nut	2		
L-1-18-2	1/2" Elbow	1	140538-0-00	L-1-18 Solenoid Valve Assembly 149543-0-01	L-7	Bead Band	1		
L-1-18-3	Solenoid Valve	1	149544-0-01		L-8	Screw	2		
L-1-18-4	1/2" Cap	1	140542-0-01		L-9	Cushion Rubber	2		
L-1-18-5	Valve Connector	2	140539-0-00						

# M. Control Box

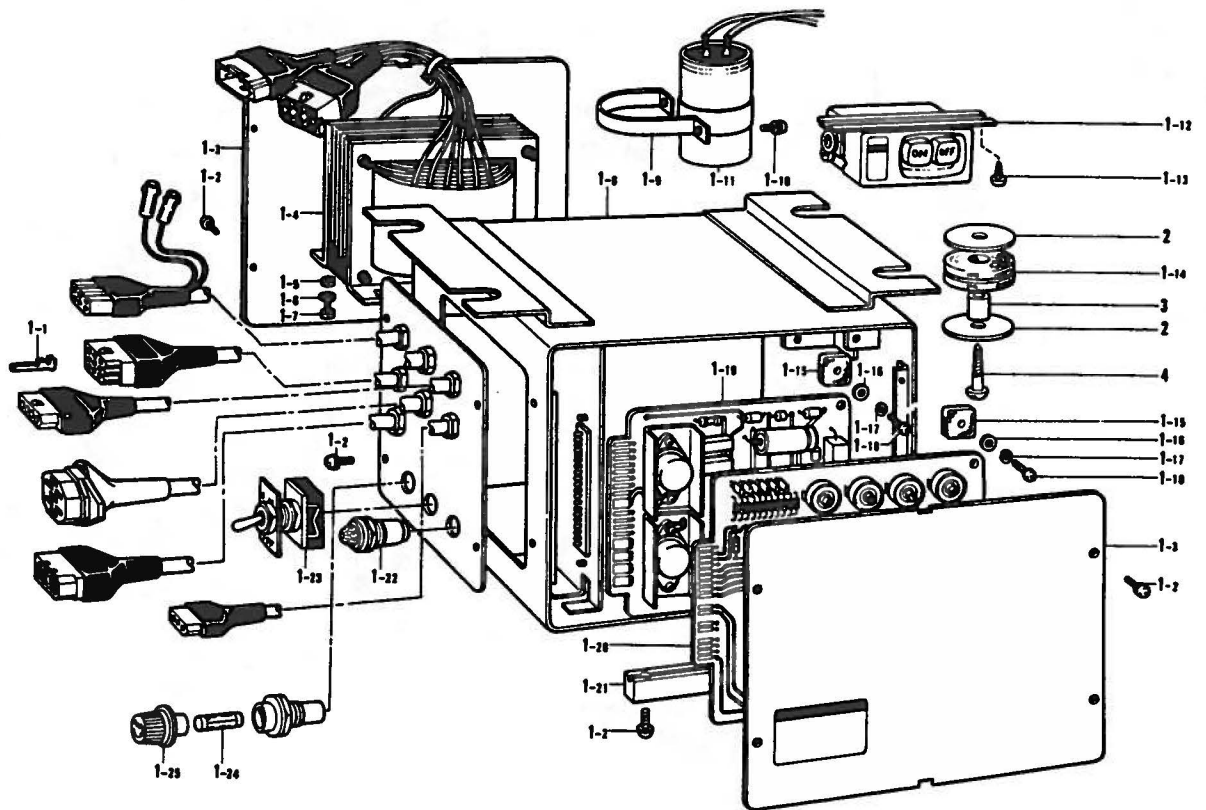

Ref. No.	Name of Parts	Q'ty	Parts No.	Assembly No.	Ref. No.	Name of Parts	Q'ty	Parts No.	Assembly No.
M-1- 1	Terminal Pin	27	216373-0-01	M-1 Control Box Assembly	M-1-15	Insulator Rubber	2	216351-0-00	M-1 Control Box Assembly
M-1- 2	Screw	16	215080-0-01		M-1-16	Washer	4	025030-3-35	
M-1- 3	Control Box Front Cover Plate	2	218819-0-01		M-1-17	Washer	2	028030-2-43	
M-1- 4	Transformer	1			M-1-18	Screw	4	002300-8-05	
M-1- 5	Nut	4	218823-0-01		M-1-19	Printed Circuit Board	1		
M-1- 6	Washer	4	025040-2-35		M-1-20	Printed Circuit Board	1		
M-1- 7	Screw	4	216870-0-01		M-1-21	Mounting Rail	2	218821-0-01	
M-1- 8	Control Box	1			M-1-22	Pilot Lamp	1		
M-1- 9	Condenser Set Plate	1			M-1-23	Pilot Lamp Switch	1	216905-0-01	
M-1-10	Screw	2			M-1-24	5A Fuse	1	215822-0-00	
M-1-11	Condenser	1			M-1-25	Fuse Holder	1	215387-0-01	
M-1-12	3P Push Button Switch	1	213794-0-01		M-2	Washer	8	214344-0-01	
M-1-13	Screw	2	031451-6-03		M-3	Collar	4	216346-0-01	
M-1-14	Cushion Rubber	4	216345-0-00		M-4	Screw	4	031624-0-05	



# N. Motor (Part 1)

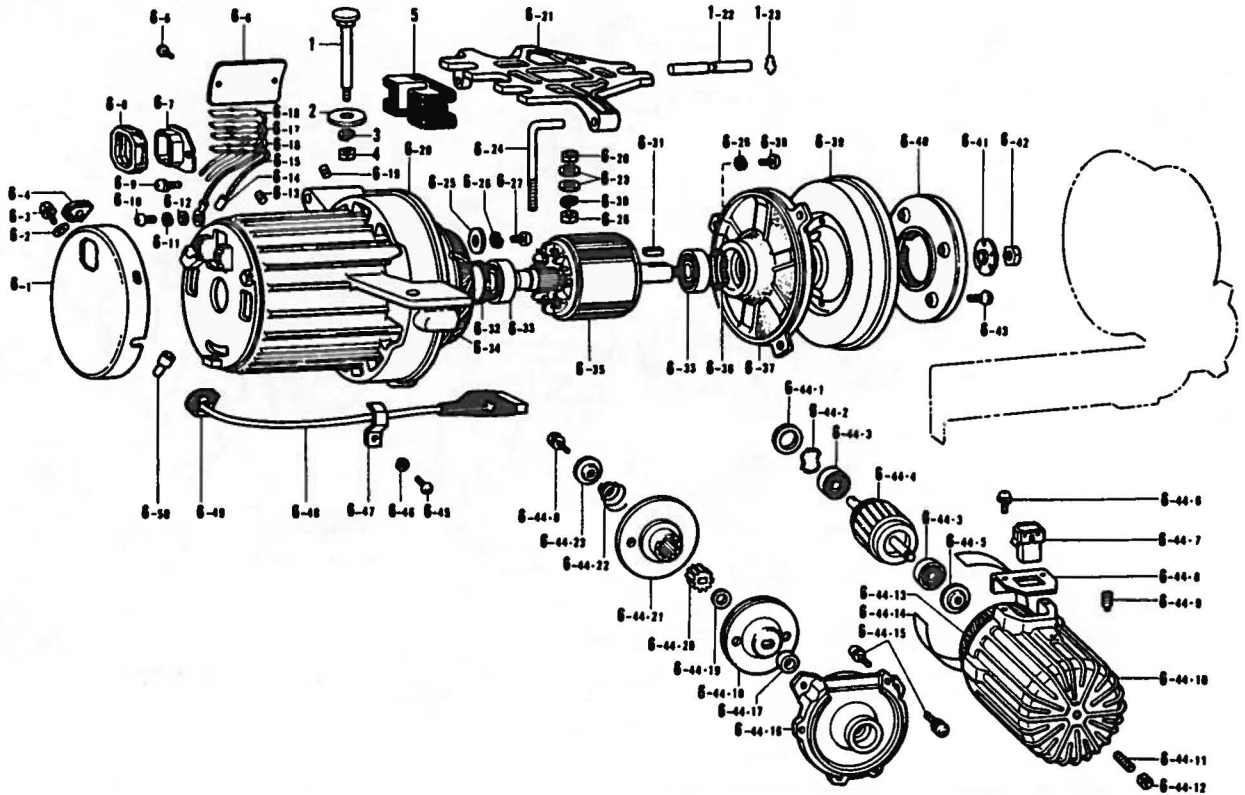

Ref. No.	Name of Parts	Q'ty	Parts No.	Assembly No.	Ref. No.	Name of Parts	Q'ty	Parts No.	Assembly No.
N-1	Bolt	3	210973-0-01		N-6-35	Rotor	1		
N-2	Washer	3	213650-0-01		N-6-36	Washer	1	206156-0-01	
N-3	Washer	3	028080-2-43		N-6-37	Bracket	1	218871-0-01	
N-4	Nut	3	021080-1-06		N-6-38	Screw	3	002501-6-05	
N-5	Vibration Absorbing Rubber	3	213646-0-01		N-6-39	Fly Wheel	1		
N-6- 1	Frame Cover	1	218863-0-01		N-6-40	Clutch Lining #4	1	218873-0-00	
N-6- 2	Washer	3	025050-2-35		N-6-41	Washer	1	210941-0-02	
N-6- 3	Screw	3	211528-0-01		N-6-42	Nut	1	210942-0-02	
N-6- 4	Rubber Pad #72	1	218865-0-01		N-6-43	Screw	4	214897-0-01	
N-6- 5	Pin	2	200084-0-02		N-6-44- 1	Washer	2	218913-0-01	
N-6- 6	Model Plate	1			N-6-44- 2	Washer	3	218870-0-01	
N-6- 7	7P Socket	1	213748-0-01		N-6-44- 3	Bearing 608 VV	2	072060-8-60	
N-6- 8	7P Socket Cover 1	1	218862-0-01		N-6-44- 4	Roter	1		
N-6- 7	Screw	2	008400-8-06		N-6-44- 5	Roter Push Plate	1	218910-0-00	
N-6-10	Screw	1	002401-0-63		N-6-44- 6	Screw	3	215080-0-01	
N-6-11	Washer	1	028040-2-43		N-6-44- 7	3P Plug	1	216299-0-01	
N-6-12	Nut	1	025040-1-73		N-6-44- 8	Plug Set Plate	1	216300-0-01	
N-6-13	Screw	1	013080-8-13		N-6-44- 9	Screw	1	216286-0-01	
N-6-14	Vinyl Cap for Lead Wire	2	218951-0-01		N-6-44-10	Sub Motor Frame #55	1	218911-0-01	
N-6-15	Lead Wire (White)		218861-0-01		N-6-44-11	Screw	1	012061-8-22	
N-6-16	Lead Wire for Earth	1			N-6-44-12	Nut	1	021060-3-05	
N-6-17	Lead Wire (Red)	1	218861-0-02		N-6-44-13	Stator	1		
N-6-18	Lead Wire (Black)	1	218861-0-03		N-6-44-14	Insulator Paper	2	216284-0-00	
N-6-19	Screw	1	011060-6-13		N-6-44-15	Screw	3	211528-0-01	
N-6-20	Frame #54	1	218831-0-01		N-6-44-16	Bracket	1	218912-0-00	
N-6-21	Base	1	218874-0-01		N-6-44-17	Collar	1	218922-0-01	
N-6-22	Pin	1	218875-0-01		N-6-44-18	Clutch Plate	1	218916-0-01	
N-6-23	Washer	1	213765-0-01		N-6-44-19	Washer	1	218921-0-01	
N-6-24	Bolt Adjusting Rod	1	210965-0-01		N-6-44-20	Selation	1	217280-0-01	
N-6-25	Washer	3	213752-0-01		N-6-44-21	Round Plate	1	218918-0-01	
N-6-26	Spring Washer	6	028050-2-43		N-6-44-22	Spring	1	218919-0-01	
N-6-27	Screw	3	218905-0-01		N-6-44-23	Washer	1	218920-0-00	
N-6-28	Nut	2	021100-2-06		N-6-45	Screw	1	002500-8-06	
N-6-29	Washer	2	025100-2-36		N-6-46	Spring Washer	1	028050-2-43	
N-6-30	Washer	1	028100-2-43		N-6-47	Cord Holder	1	218866-0-01	
N-6-31	Key	1	210940-0-00		N-6-48	Plug for Sub Motor	1	218867-0-01	
N-6-32	Rubber Washer 708 X 35 X 40RU	1	210938-0-01		N-6-49	Rubber Pad #71	1	218864-0-01	
N-6-33	Bearing 6203 VV	2	072620-3-60		N-6-50	Crimp Connector	3	217169-0-00	
N-6-34	Stator	1							

N-6 Motor Assembly

N-6-44 Sub Motor Assembly

# N. Motor (Part 2 )

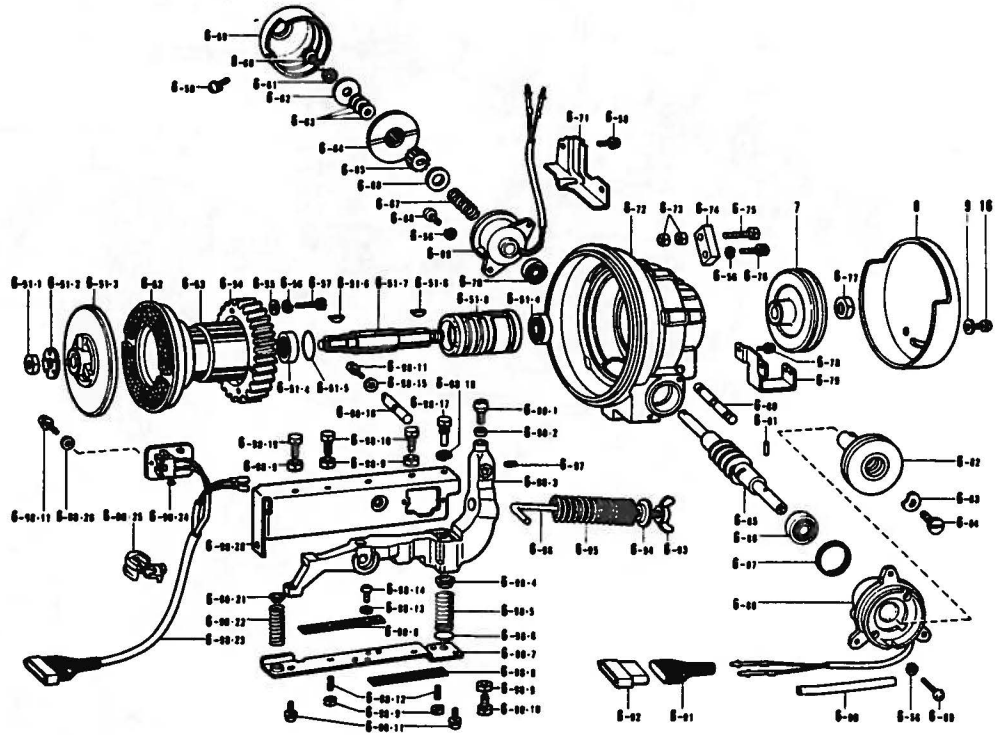

Ref. No.	Name of Parts	Q'ty	Parts No.	Assembly No.	Ref. No.	Name of Parts	Q'ty	Parts No.	Assembly No.
N-6-51-1	Nut	1	210942-0-02	N-6-51 Clutch Plate #8 Assembly 218877-0-01	N-6-86	Bearing 6201 VV	1	072620-1-61	N-6-98 Clutch Lever #8 Assembly 218923-0-01
N-6-51-2	Washer	1	210941-0-02		N-6-87	Washer	1	216277-0-01	
N-6-51-3	Clutch Plate #6	1	213750-0-00		N-6-88	Clutch Solenoid	1	218903-0-01	
N-6-51-4	Bearing 620 VV	2	072620-2-60		N-6-89	Screw	2	002503-5-03	
N-6-51-5	Washer	1	210948-0-01		N-6-90	Vinyl Tube	1	216837-0-11	
N-6-51-6	Key	2	210421-0-00		N-6-91	Plug Cover	1	216248-0-01	
N-6-51-7	Clutch Shaft	1	218878-0-00		N-6-92	4P Plug	1	216247-1-01	
N-6-51-8	Clutch Shaft Supporter	1	218879-0-01		N-6-93	Nut	1	206337-0-02	
N-6-52	Brake Lining	1	218882-0-00	N-6-94	Spring Cap	1	213761-0-01		
N-6-53	Supporter for Clutch Shaft Supporter	1	290439-0-00	N-6-95	Spring	1	218923-0-01		
N-6-54	Gear 1/2	1	216219-0-00	N-6-96	Pedal Pressure Adjusting Screw	1	218928-0-01		
N-6-55	Washer	4	025050-1-35	N-6-97	Screw	1	014061-0-22		
N-6-56	Washer	9	028050-2-43	N-6-98-1	Ball Screw	1	216225-0-01		
N-6-57	Screw	4	018502-5-22	N-6-98-2	Nut	1	218921-0-01		
N-6-58	Screw	4	215080-0-01	N-6-98-3	Clutch Lever	1	218924-0-01		
N-6-59	Brake Cover	1	218902-0-01	N-6-98-4	Spring Cap	1	216233-0-01		
N-6-60	Bolt	1	018401-4-22	N-6-98-5	Spring	1	218945-0-01		
N-6-61	Spring Washer	1	028040-2-43	N-6-98-6	Washer	1	216235-0-00		
N-6-62	Washer	1	218896-0-00	N-6-98-7	Clutch Lever Bottom Plate	1	218946-0-01		
N-6-63	Spacer	4	218860-0-01	N-6-98-8	Switch Presser Plate	2	216241-0-01		
N-6-64	Brake Disc	1	218895-0-01	N-6-98-9	Nut	6	021060-3-05		
N-6-65	Setation	1	217280-0-01	N-6-98-10	Bolt	3	213913-0-01		
N-6-66	Washer	1	218894-0-01	N-6-98-11	Screw	8	215080-0-01		
N-6-67	Spring	1	218893-0-01	N-6-98-12	Screw	2	012061-2-22		
N-6-68	Screw	2	002501-6-05	N-6-98-13	Spring Washer	2	028040-2-43		
N-6-69	Brake Solenoid	1	218915-0-01	N-6-98-14	Screw	2	002400-6-05		
N-6-70	Bearing 608 VV	1	072060-8-60	N-6-98-15	Washer	1	025040-3-35		
N-6-71	Cord Holder	1	218930-0-01	N-6-98-16	Pin	1	218926-0-01		
N-6-72	Bracket	1	218876-0-01	N-6-98-17	Bolt	1	216232-0-01		
N-6-73	Nut	2	021060-3-05	N-6-98-18	Washer	1	028060-2-43		
N-6-74	Space Adjusting Plate	1	218881-0-01	N-6-98-19	Bolt	1	214002-0-01		
N-6-75	Bolt	1	219405-0-01	N-6-98-20	Clutch Lever Cover	1	218925-0-01		
N-6-76	Bolt	1	018502-2-23	N-6-98-21	Spring Cap	1	218927-0-01		
N-6-77	Nut	1	210240-0-01	N-6-98-22	Spring	1	216230-0-01		
N-6-78	Screw	2	211528-0-01	N-6-98-23	Micro Key Cord	1	218947-0-01		
N-6-79	Belt Cover Set Plate	1	216380-0-01	N-6-98-24	Micro Switch	2	216236-0-01		
N-6-80	Pin	1	213757-0-02	N-6-98-25	Bushing	1	212544-0-01		
N-6-81	Spring Pin	1	218952-0-01	N-6-98-26	Washer	4	025040-1-35		
N-6-82	Clutch Plate #2	1	218885-0-01	N-7	Pulley	1			
N-6-83	Washer	1	218891-0-01	N-8	Belt Cover	1	215491-0-01		
N-6-84	Screw	1	218892-0-01	N-9	Washer	2	025050-3-35		
N-6-85	Worm 1/2	1	218884-0-00	N-10	Screw	2	211528-0-01		



# U. Bobbin Winder Mechanism

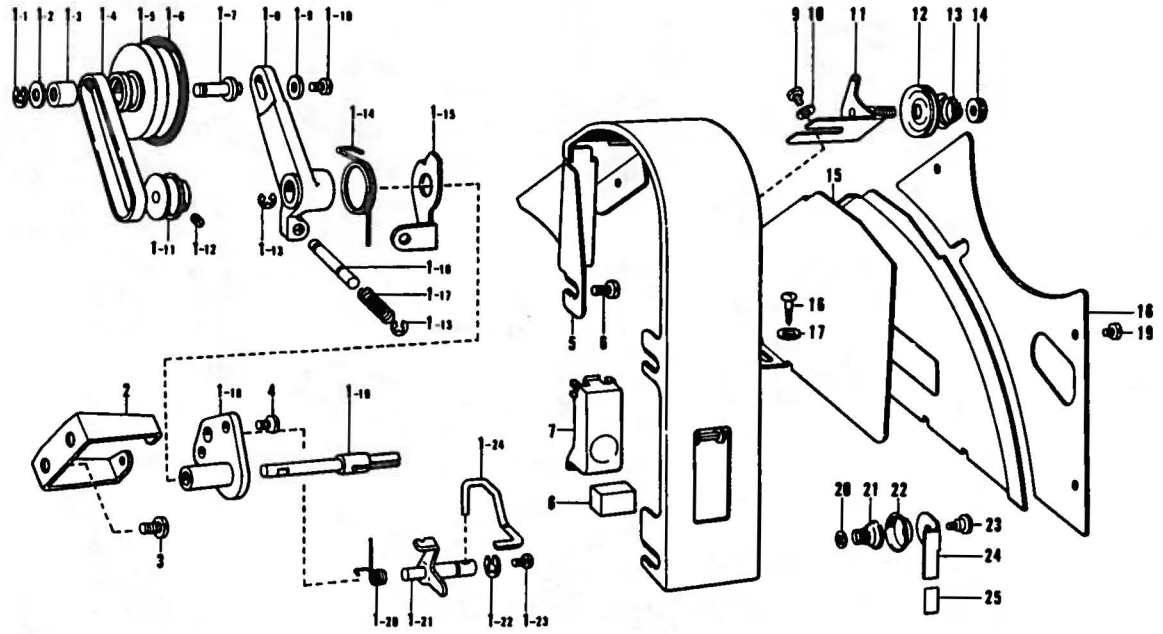

Ref. No.	Name of Parts	Q'ty	Parts No.	Assembly No.	Ref. No.	Name of Parts	Q'ty	Parts No.	Assembly No.
U-1-1	Clip Ring	1	048050-3-42	U-1 Bobbin Winder Assembly 147549-0-01	U- 2	Bobbin Winder Supporter	1	148051-0-01	
U-1-2	Washer	1	025770-2-32		U- 3	Screw	2	009760-8-13	
U-1-3	Needle Bearing	1	147568-0-01		U- 4	Screw	2	009680-6-12	
U-1-4	V Belt	1	145684-0-01		U- 5	Belt Cover Assembly	1	145567-0-01	
U-1-5	Bobbin Winder Driving Pulley	1	148050-0-00		U- 6	Screw	3	009760-8-13	
U-1-6	Rubber Ring	1	145558-0-01		U- 7	Push Button	1	145682-0-01	
U-1-7	Bobbin Winder Driving Pulley Stud	1	148049-0-01		U- 8	Cushion	1	151608-0-01	
U-1-8	Bobbin Winder Driving Pulley Supporter	1	148044-0-01		U- 9	Screw	1	001670-6-12	
U-1-9	Washer	1	025350-3-32		U-10	Washer	2	025350-3-32	
U-1-10	Screw	1	009670-6-12		U-11	Bobbin Winder Guide Bracket Assembly	1	145571-1-01	
U-1-11	Bobbin Winder Belt Wheel	1	148048-0-01		U-12	Tension Disc	2	145446-0-01	
U-1-12	Screw	2	013670-7-12		U-13	Tension Spring	1	100401-0-01	
U-1-13	Stop Ring	2	048030-3-42		U-14	Nut	1	100136-0-01	
U-1-14	Return Spring	1	148045-0-01		U-15	Belt Cover Lower	1	145570-0-01	
U-1-15	Bobbin Winder Presser Plate	1	147538-0-01		U-16	Screw	2	100666-0-02	
U-1-16	Bobbin Winder Button Stud	1	147540-0-01		U-17	Washer	2	025750-1-32	
U-1-17	Spring	1	147539-0-01		U-18	Belt Cover Lid	1	147548-0-01	
U-1-18	Bobbin Winder Bracket	1	148043-0-01		U-19	Screw	2	009680-5-12	
U-1-19	Bobbin Winder Shaft	1	148047-0-01		U-20	Stop Ring	1	146200-0-01	
U-1-20	Cam Stud Spring	1	148046-0-01		U-21	Spring	1	144505-0-00	
U-1-21	Cam Shaft	1	147542-0-01		U-22	Disc	1	146199-0-01	
U-1-22	Clip Ring	1	048050-3-42		U-23	Screw	1	118764-0-02	
U-1-23	Screw	1	009670-6-12		U-24	Knife	1	146198-0-01	
U-1-24	Bobbin Presser	1	147547-0-01		U-25	Cushion	1	146289-0-01	



## Z. Accessories

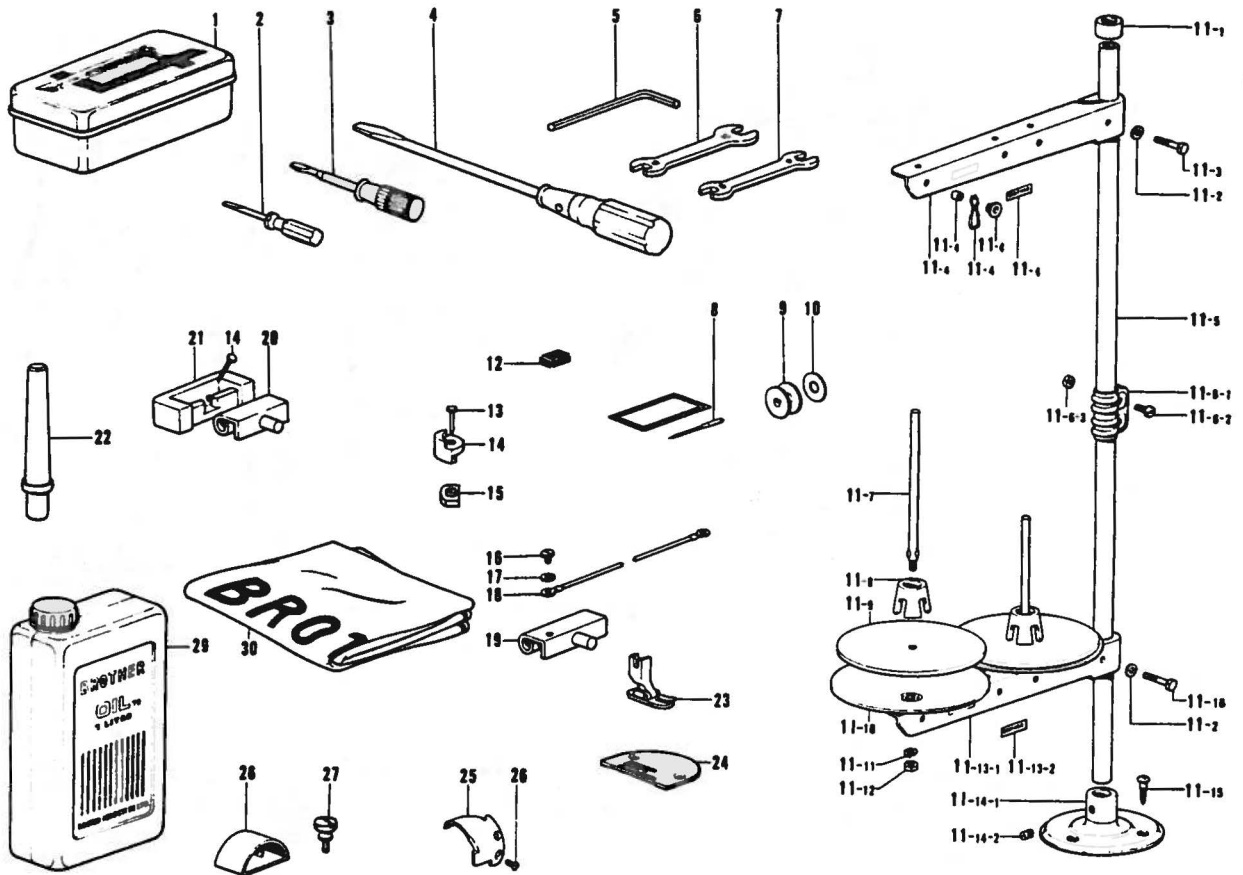

Ref. No.	Name of Parts	Q'ty	Parts No.	Assembly No.	Ref. No.	Name of Parts	Q'ty	Parts No.	Assembly No.
Z- 1	Accessory Box		110436-0-01		Z-11-13	Spool Holder Assembly		150177-0-01	
Z- 2	Screw Driver		142443-0-01		Z-11-14-1	Cotton Stand Base		150189-0-01	Z-11-14 Cotton Stand Base Assembly 150189-0-01
Z- 3	Screw Driver		118837-0-01		Z-11-14-2	Screw		150181-0-01	
Z- 4	Screw Driver		101572-1-01		Z-11-15	Screw		031452-2-03	
Z- 5	Spanner		146049-0-01		Z-11-16	Bolt		017502-8-03	
Z- 6	Spanner 10 X 12		107780-0-01		Z-12	Magnet		112525-0-00	
Z- 7	Spanner 8 X 9		100887-0-01		Z-13	Nail		109714-0-00	
Z- 8	Needle				Z-14	Head Cushion		146003-1-01	
Z- 9	Bobbin		100376-0-01		Z-15	Oil Pan Cushion		146004-0-01	
Z-10	Bobbin Case Sheet		140356-0-01		Z-16	Screw		009680-6-13	
Z-11- 1	Cap				Z-17	Washer		025680-2-34	
Z-11- 2	Washer		025050-2-33		Z-18	Earth Wire		145946-0-01	
Z-11- 3	Bolt		017502-8-03		Z-19	Head Hinge		145945-0-01	
Z-11- 4	Thread Hanger Assembly		150192-0-01		Z-20	Hinge		143882-0-01	
Z-11- 5	Pipe		150172-0-01		Z-21	Rubber Hinge		143910-0-01	
Z-11- 6-1	Joint		150173-0-01	Z-11-6 Joint Assembly 150106-0-01	Z-22	Head Rest		100477-0-01	
Z-11- 6-2	Screw		150202-0-01		Z-23	Presser Foot		40957-0-01	
Z-11- 6-3	Nut		021500-1-03		Z-24	Needle Plate		100266-0-01	
Z-11- 7	Spool Shaft		150179-0-01		Z-25	Movable Knife		145608-0-01	
Z-11- 8	Spool Cushion		147060-0-01		Z-26	Screw		141542-0-01	
Z-11- 9	Spool Mat		150182-0-00	Z-11 Cotton Stand Assembly 150150-0-01	Z-27	Thumb Screw		106120-0-01	
Z-11-10	Spool Stand Base		150180-0-00		Z-28	Movable Knife Case		145990-0-01	
Z-11-11	Spring Washer		028050-2-43		Z-29	Oil Tank		145277-1-03	
Z-11-12	Nut		021500-1-03		Z-30	Head Cover		144222-0-01	

\*The details of included accessories are subject to change.

\*Änderungen in der Aufstellung der mitgelieferten Zubehöre sind vorbehalten.

\*Les détails des accessoires inclus sont sujets à des changements.

\*Los detalles de los accesorios incluidos pueden variar.

# DIFFERENT PARTS LIST

Ref. No.	Name of Parts	Sub-Class		-103		-105		-203		-205	
		Motor Spec.		Brother	Efka	Brother	Efka	Brother	Efka	Brother	Efka
A-4	Face Plate			145523-0-01				146078-0-01			
A-37	Tension Regulator Assembly			181634-0-01		181635-0-01		181634-0-01		181635-0-01	
A-37-8	Tension Spring			145520-0-01		145153-0-01		145520-0-01		145153-0-01	
B-1	Needle DB x 1			100265-0-34		100265-0-42		100265-0-34		100265-0-42	
B-5	Needle Bar Bushing			145468-0-01		146311-0-01		145468-0-01		146311-0-01	
B-8	Thread Take-up Lever Assembly			147551-0-01		149313-0-01		147551-0-01		149313-0-01	
B-10	Needle Bar			111462-0-01		145986-0-01		111462-0-01		145986-0-01	
B-11	Block for Needle Bar Guide			102630-0-01		146366-0-01		102630-0-01		146366-0-01	
B-52	Rotary Hook Assembly			145585-1-01		148846-0-01		145585-1-01		148846-0-01	
B-54	Bobbin Case Holder Position Bracket			100367-0-01		147337-0-01		100367-0-01		147337-0-01	
B-61	Needle Plate Washer			146188-0-01		146251-0-01		146188-0-01		146251-0-01	
B-62	Needle Plate			145971-0-01		147245-0-01		145971-0-01		147245-0-01	
C-10	Length Control Assembly			181632-1-01		181482-1-01		181632-1-01		181482-1-01	
C-10-4	Length Control Plate			151508-0-01		151507-0-01		151508-0-01		151507-0-01	
C-15	Screw					100511-0-03					
C-16	Reverse Lever					147503-0-01					
C-17	Screw Lever Plate			009711-4-12				009711-4-12			
C-19	Reverse					147504-0-01					
C-23	Reverse Lever Shaft					147505-0-01					
C-25	Spring					150757-0-01					
C-26	Reverse Lever Stopper										
C-27	Reverse Lever Presser Spring										
C-28	Collar										
C-29	Reverse Lever										
C-30	Washer										
C-31	Screw										
C-32	Reverse Lever Shaft										
C-39	Feed Dog			100334-0-01		144500-0-01		100334-0-01		144500-0-01	
D-1	Presser Foot			113280-0-01		145157-0-01		113280-0-01		145157-0-01	
D-17	Tension Releaser					145689-0-01					
D-22	Spring					145475-1-01					
D-30	Knee Lifter Assembly					181427-0-01					
E-30	Oil Pan Assembly					181420-2-01					
E-30-4	Oil Pan					149580-0-01					
E-30-11	Spring					146038-0-01					
E-30-12	Knee Lifter Shaft					146036-1-01					
E-30-14	Spring										
F-17	Solenoid Bracket Assembly			150375-0-01	152187-0-01	150375-0-01	152187-0-01	150375-0-01	152187-0-01	150375-0-01	152187-0-01
F-17-5	Thread Trimming Solenoid Assembly			149108-0-01	152188-0-01	149108-0-01	152188-0-01	149108-0-01	152188-0-01	149108-0-01	152188-0-01
F-17-5-3	Terminal Pin			143549-0-00		143549-0-00		143549-0-00		143549-0-00	
F-22	Connector Cap			145596-0-01		145596-0-01		145596-0-01		145596-0-01	
F-23	Nylon Connector			145681-0-00		145681-0-00		145681-0-00		145681-0-00	
F-33	Spacer			145611-0-00		146187-0-00		145611-0-00		146187-0-00	
G-2	Synchronizer Assembly			218931-0-01		218931-0-01		218931-0-01		218931-0-01	
G-6	Slip Ring Support				148825-0-01		148825-0-01		148825-0-01		148825-0-01
H-5	Cord			146095-0-00	151183-0-01	146095-0-00	151183-0-01	146095-0-01	151183-0-01	146095-0-00	151183-0-01
H-5-4	Terminal Pin			143549-0-00		143549-0-00		143549-0-00		143549-0-00	
H-23	Supporter									140647-0-01	
H-24	Tube Holder										
H-29	Switch										
H-29-2	Terminal Pin										
J-3	Reverse Solenoid										
J-3-5	Terminal Pin										
J-9	Connector Cap										
J-10	6P Connector										
L-1	Air Control Box										
L-2	Presser Foot Lifter Cord Assembly										
L-3	Screw										
L-4	Washer										
L-5	Washer										
L-6	Nut										
L-7	Bead Band										
L-8	Screw										
L-9	Cushion Rubber										
Z-8	Needle DB x 1			100265-0-34		100265-0-42		100265-0-34		100265-0-42	



Ref. No.	Name of Parts	Sub-Class Motor Spec.	-403		-405		-503		-505	
			Brother	Efka	Brother	Efka	Brother	Efka	Brother	Efka
A-4	Face Plate		146078-0-01							
A-37	Tension Regulator Assembly		181634-0-01		181635-0-01		181634-0-01		181635-0-01	
A-37-8	Tension Spring		145520-0-01		145153-0-01		145520-0-01		145153-0-01	
B-1	Needle DB x 1		100265-0-34		100265-0-42		100265-0-34		100265-0-42	
B-5	Needle Bar Bushing		145468-0-01		146311-0-01		145468-0-01		146311-0-01	
B-8	Thread Take-up Lever Assembly		147551-0-01		149313-0-01		147551-0-01		149313-0-01	
B-10	Needle Bar		111462-0-01		145986-0-01		111462-0-01		145986-0-01	
B-11	Block for Needle Bar Guide		102630-0-01		146366-0-01		102630-0-01		146366-0-01	
B-52	Rotary Hook Assembly	15313-901	145685-1-01		148846-1-01		145685-1-01	15313-901	148846-1-01	
B-54	Bobbin Case Holder Position Bracket		100367-0-01		147337-0-01		100367-0-01		147337-0-01	
B-61	Needle Plate Washer		146188-0-01		146251-0-01		146188-0-01		146251-0-01	
B-62	Needle Plate		145971-0-01		147245-0-01		145971-0-01		147245-0-01	
C-10	Length Control Assembly		181632-1-01		181482-1-01		181632-1-01		181482-1-01	
C-10-4	Length Control Plate		151508-0-01		151507-0-01		151508-0-01		151507-0-01	
C-15	Screw									
C-16	Reverse Lever									
C-17	Screw Lever Plate									
C-19	Reverse									
C-23	Reverse Lever Shaft									
C-25	Spring			147598-0-01				150757-0-01		
C-26	Reverse Lever Stopper					149083-0-01				
C-27	Reverse Lever Presser Spring					149088-0-01				
C-28	Collar					149087-0-01				
C-29	Reverse Lever					149086-0-01				
C-30	Washer					116662-0-03				
C-31	Screw					009710-8-12				
C-32	Reverse Lever Shaft					149085-0-01				
C-39	Feed Dog		100334-0-01		144500-0-01		100334-0-01		144500-0-01	
D-1	Presser Foot		113280-0-01		145157-0-01		113280-0-01		145157-0-01	
D-17	Tension Releaser			145689-0-01				147198-0-01		
D-22	Spring			145475-1-01				147197-0-01		
D-30	Knee Lifter Assembly			181427-0-01						
E-30	Oil Pan Assembly			181420-2-01				181430-2-01		
E-30-4	Oil Pan			149580-0-01				149581-0-01		
E-30-11	Spring			146038-0-01						
E-30-12	Knee Lifter Shaft			146036-1-01				146069-0-01		
E-30-14	Spring							146985-0-01		
F-17	Solenoid Bracket Assembly		150375-0-01	152187-0-01	150375-0-01	152187-0-01	150375-0-01	152187-0-01	150375-0-01	152187-0-01
F-17-5	Thread Trimming Solenoid Assembly		149108-0-01	152188-0-01	149108-0-01	152188-0-01	149108-0-01	152188-0-01	149108-0-01	152188-0-01
F-17-5-3	Terminal Pin		143549-0-00		143549-0-00		143549-0-00		143549-0-00	
F-22	Connector Cap		145596-0-01		145596-0-01		145596-0-01		145596-0-01	
F-23	Nylon Connector		145681-0-00		145681-0-00		145681-0-00		145681-0-00	
F-33	Spacer		145611-0-00		146187-0-00		145611-0-00		146187-0-00	
G-2	Synchronizer Assembly		218931-0-1		218931-0-01		218931-0-01		218931-0-01	
G-6	Slip Ring Support			148825-0-01		148825-0-01		148825-0-01		148825-0-01
H-5	Cord		146095-0-00	151183-0-01	146095-0-00	151183-0-01	146095-0-00	151183-0-01	146095-0-00	151183-0-01
H-5-4	Terminal Pin		143549-0-00		143549-0-00		143549-0-00		143549-0-00	
H-23	Supporter									
H-24	Tube Holder					142268-0-01				
H-29	Switch		146121-0-00	151185-0-01	146121-0-00	151185-0-01	146121-0-00	151185-0-01	146121-0-00	151185-0-01
H-29-2	Terminal Pin		143549-0-00		143549-0-00		143549-0-00		143549-0-00	
J-3	Reverse Solenoid		147756-0-01	151181-0-01	147756-0-01	151181-0-01	147756-0-01	151181-0-01	147756-0-01	151181-0-01
J-3-5	Terminal Pin		143549-0-00		143549-0-00		143549-0-00		143549-0-00	
J-9	Connector Cap		145596-0-01		145596-0-01		145596-0-01		145596-0-01	
J-10	6P Connector		146118-0-00		146118-0-00		146118-0-00		146118-0-00	
L-1	Air Control Box						149539-0-01		149539-0-01	
L-2	Presser Foot Lifter Cord Assembly						146160-0-01		146160-0-01	
L-3	Screw						002303-0-06		002303-0-06	
L-4	Washer						025030-2-33		025030-2-33	
L-5	Washer						028030-2-43		028030-2-43	
L-6	Nut						021300-1-03		021300-1-03	
L-7	Bead Band						144189-0-01		144189-0-01	
L-8	Screw						031483-2-03		031483-2-03	
L-9	Cushion Rubber						115018-0-01		115018-0-01	
Z-8	Needle DB x 1		100265-0-34		100265-0-42		100265-0-34		100265-0-42	



Ref.No.	Phase Name of Parts	Volt	3 Phase				1 Phase			
			220V	380V	400V	400V (Lamp tap 12V)	110V	220V	240V	240V (Lamp tap 12V)
M-1	Control Box Assembly	200	220970-0-01	220966-0-01	220965-0-01		220971-0-01	220972-0-01		
		400					220974-0-01	221051-0-01		
		500	220967-0-01	220968-0-01	220969-0-01		220975-0-01	220976-0-01	220977-0-01	
M-1-4	Transformer	219749-0-00	219501-0-00	219505-0-00		220001-0-00	219749-0-00	219744-0-00		
M-1-9	Condenser Set Plate						219746-0-01			
M-1-10	Screw						215080-0-01			
M-1-11	Condenser						220010-0-01	219745-0-01		
M-1-19	Printed Circuit Board	200/400	219698-0-01							
		500	220070-0-01							
M-1-20	Printed Circuit Board	200/500	219752-0-01							
		400	219699-0-01							
M-1-22	Pilot Lamp	216364-0-00				217249-0-00	216364-0-00			
N-6	Motor Assembly	219972-0-01	219497-0-01	219934-0-01	219507-0-01	219984-0-01	219733-0-01	219967-0-01	219726-0-01	219791-0-01
N-6-34	Stator	219485-0-01	219483-0-00	219935-0-00	219484-0-00	219985-0-00	219734-0-00	219968-0-00	219728-0-00	219792-0-00
N-6-35	Roter	213802-0-01				217805-0-01				
N-6-39	Fly Wheel	218872-0-01				219729-0-01				
N-6-44	Sub Motor Assembly	219973-0-01	219499-0-01	219509-0-01		219986-0-01	219735-0-01	219730-0-01		
N-6-44-4	Roter	218907-0-01				219235-0-01				
N-6-44-13	Stator	219488-0-00	219486-0-00	219487-0-00		219987-0-00	219736-0-00	219731-0-00		
N-6-16	Lead Wire for Earth	213792-0-01				213792-0-01				
N-6-15Q'ty	Lead Wire (White)	2				1				

Ref. No.	Name of Parts	Parts No.	Sewing Speed			
			50Hz		60Hz	
			High Speed	Slow Speed	High Speed	Slow Speed
N-7	Pulley K- 75	216921-0-01			3550	165
	Pulley K- 80	217135-0-01			3850	180
	Pulley K- 85	216922-0-01	3400	160	4050	190
	Pulley K- 90	216923-0-01	3650	170	4300	205
	Pulley K- 95	217136-0-01	3850	180		
	Pulley K-100	216924-0-01	4050	190		
	Pulley K-105	216925-0-01	4250	200		

# INDEX

Parts No.	Ref. No.	Remark	Parts No.	Ref. No.	Remark	Parts No.	Ref. No.	Remark	Parts No.	Ref. No.	Remark
001670-5-14	H-21		011060-6-13	N- 6-19		028040-2-43	N- 6-61		100511-0-03	C-15	
001670-6-12	F- 7		011711-4-12	A-40		028050-2-43	N- 6-98-13		100645-0-03	F-38	
	F-12		012061-2-22	N- 6-98-12			L- 1- 8		F-17-10		
	U- 9		012061-8-22	N- 6-44-11			Z-11-11		100666-0-02	U-16	
001671-0-14	D- 2		013080-8-13	N- 6-13		N- 6-26		100887-0-01	Z- 7		
002300-8-05	M- 1-18		013670-7-12	U- 1-12		N- 6-46		101487-0-00	B-28		
002301-0-03	L- 1-14		013679-4-12	F-17-16		N- 6-56		101572-1-01	Z- 4		
002303-0-06	L- 3		013710-5-12	D-11		028060-2-34	G- 2-12		101706-0-01	F-25	
002400-6-05	N- 6-98-14		013760-6-10	B-34		028060-2-40	K- 1		101706-0-03	B-42- 2	
002401-0-63	N- 6-10			B-40		028060-2-43	N- 6-98-18			B-49- 2	
002401-2-03	L- 1-19			D- 4- 2		028080-2-43	N- 3		102538-0-02	E-15	
002500-8-06	N- 6-45		013761-4-10	B-37		028100-2-43	N- 6-30		102630-0-01	B-11	
002501-0-64	L- 1- 6			B-44		031451-6-03	M- 1-13		102716-0-02	H-14	
002501-6-05	N- 6-38		013781-0-12	B-15		031452-2-03	Z-11-15		103950-0-02	A-38	
002503-5-05	N- 6-68		014061-0-22	N- 6- 97		031483-2-03	L- 8		104449-0-01	A- 2	
	N- 6-89		014680-6-22	F-29		031624-0-05	M- 4			A- 8	
007401-0-12	F-17- 1		017502-8-03	Z-11- 3		048025-3-42	H- 9		104450-0-01	A- 6	
007500-6-02	J- 1			Z-11-16		048030-3-40	F-17- 9		104451-0-01	A-29	
007500-8-12	J- 8		017762-0-13	D-30- 2		048030-3-42	D-18		104464-0-01	B-23	
007670-5-13	C-18			K-10			F-17-23		104520-0-00	B-47	
008400-5-64	L- 1- 2		018401-4-22	N- 6-60			U- 1-13		104546-0-01	E-14	
008400-8-06	N- 6- 9		018502-2-23	N- 6-76		048040-3-42	D-21		104547-0-01	E-13	
009660-7-12	F-46		018502-5-22	N- 6-57			J- 4		104555-0-01	B-27	
	F-52		021060-3-05	N- 6-44-12			J-20		104564-0-01	C-22	
009670-4-12	B-32			N- 6-73			J-24		104567-0-01	C-56	
009670-5-12	E- 2			N- 6-98-9			K- 5		104619-0-02	D-30- 3	
009670-5-13	E- 6		021080-1-06	N- 4					104689-0-01	C- 6	
	J-15		021100-2-06	N- 6-28		048050-3-42	U- 1- 1			C-14	
009670-6-12	B-12		021300-1-03	L- 1-10			U- 1-22		104821-0-01	A- 7	
	F- 4			L- 6		048080-3-42	C-21		104829-0-01	A-46	
	F-21		021400-1-03	L- 1-20			C-33		104830-0-01	A-45	
	H-25		021500-1-03	Z-11- 6-3			H-30		104832-0-01	A-28	
	U- 1-10			Z-11-12		048090-3-42	F-17-15		104833-0-01	A-47	
	U- 1-23		021500-1-63	L- 1- 9		072060-8-60	N- 6-44-3		104847-0-01	C-40	
009670-6-14	A-36		021660-1-02	A-42		N- 6-70			C-58		
009670-8-12	A-25		021670-2-03	F-13		072620-1-61	N- 6-86		104848-0-01	C-48	
	C-45		025030-1-33	L- 1-13		072620-2-60	N- 6-51-4			C-50	
	C-54		025030-2-33	L- 4		072620-3-60	N- 6-33		104885-0-01	E-30- 9	
	E-26- 9		025030-3-35	G- 2- 3		081001-6-70	D-12		104908-0-01	C-43	
009671-0-12	H-27			M- 1-16		081002-6-70	B-26		105234-0-01	A-22	
009671-0-13	A- 1		025040-1-33	F-17- 3		081003-0-70	D-15		106120-0-01	Z-27	
	H- 7			L- 1-22		081007-0-70	E-30- 3		107149-0-01	B-18	
009671-8-13	A- 3		025040-1-35	G- 2- 9		081014-6-70	E-12		107155-0-01	B-46	
009680-5-12	G- 8			G- 2-15		100022-0-04	E-30- 8		107407-0-03	B-53	
	U-19		025040-1-35	N- 6-98-26		100032-0-03	B-63		107428-0-01	C- 7- 1	
009680-6-12	E-19		025040-1-73	N- 6-12		100080-0-03	C-38		107780-0-01	Z- 6	
	F-10		025040-2-32	F-17-24		100090-0-04	A-34		108520-0-01	A-30	
	U- 4		025040-2-35	M- 1- 6		100128-0-02	D-14		108549-0-01	C-10- 2	
009680-6-13	Z-16		025040-3-35	G- 2- 6		100134-0-01	A-37- 7		108801-0-01	E-25	
009680-7-13	A- 9			N- 6-98-15		100136-0-01	A-37- 9		108802-0-01	C-55	
	E-29		025050-1-35	N- 6-55			U-14		108804-0-01	E- 3	
	F-26		025050-2-33	Z-11- 2		100242-0-03	F-17- 7		108809-0-01	B- 9	
009680-8-12	H- 4		025050-2-35	N- 6- 2		100260-0-01	B- 6		109147-0-01	C- 5	
009681-2-12	C-47		025050-3-35	N- 9			C- 1- 1		109151-1-01	C-10- 1	
	F-39		025060-3-35	G- 2-11		100265-0-34	B- 1		109152-0-01	C-46	
009681-4-14	H-18		025100-1-32	C-20			Z- 8		109153-0-01	C-11	
	H-32		025100-2-36	N- 6-29		100265-0-42	B- 1		109173-0-01	B-57	
009681-6-12	C-57- 2		025350-3-32	U- 1- 9			Z- 8		109405-0-01	E- 1- 2	
009710-8-12	C-31			U-10		100266-0-01	Z-24			E- 4	
009711-4-12	C-17		025680-1-33	F-27		100328-0-01	C- 8		109714-0-00	Z-13	
	C-24- 2		025680-2-34	A-23		100334-0-01	C-39		109763-0-02	D-23	
	G- 1			Z-17		100367-0-01	B-54		122771-0-01	B-60- 2	
009760-8-13			025750-1-32	U-17		100376-0-01	B-55		110087-0-01	D-30- 6	
	U- 3		025770-2-32	U- 1- 2			Z- 9		110367-0-01	B-20	
	U- 6		028030-2-43	L- 1-11		100398-0-01	A-37- 5		110436-0-01	Z- 1	
009781-4-12	F-18			L- 5		100401-0-01	U-13		111443-0-01	H-16	
	G- 5			M- 1-17		100402-0-04	A-37- 1		111462-0-01	B-10	
	J-14		028040-2-43	F-17- 2		100463-0-01	D-30- 4		111463-0-01	B- 7	
009781-8-12	J- 6			L- 1-21			K- 9		111466-0-01	D- 5	
	J-17			N- 6-11		100477-0-01	Z-22		111863-0-01	B-19	



Parts No.	Ref. No.	Remark	Parts No.	Ref. No.	Remark	Parts No.	Ref. No.	Remark	Parts No.	Ref. No.	Remark
111865-0-01	A-11		143910-0-01	Z-21		145624-0-00	B-14		146196-0-01	E-27	
112467-0-02	E-26- 1		143959-1-03	L- 1- 5		145681-0-00	F-23		146198-0-01	U-24	
112525-0-00	Z-12		143960-1-01	L- 1- 5-3		145682-0-01	U- 7		146199-0-01	U-22	
113280-0-01	D- 1		143962-0-01	L- 1- 5-4		145684-0-01	U- 1- 4		146200-0-01	U-20	
			144189-0-01	L- 7		145688-0-00	B-13		146206-0-01	A-18	
114294-0-01	A-37- 3		144458-0-01	F-43		145689-0-01	D-17		146251-0-01	B-61	
114561-0-01	B-60-3		144500-0-01	C-39		145691-0-01	D-24		146253-0-00	E-16	
114931-0-01	A-13		144505-0-00	U-21		145737-0-01	E- 7		146288-0-01	H-20	
114966-0-01	D-30- 7		144741-0-01	A-37- 2		145751-0-01	B-58		146289-0-01	U-25	
114967-0-01	D-30- 5		144869-0-01	E-26- 7		145944-0-01	B- 2		146293-0-01	E-30-13	
115018-0-01	L- 9		144872-0-01	E- 28		145945-0-01	Z-19		146311-0-01	B- 5	
115663-0-01	C-34		144874-0-01	E-26- 8		145946-0-01	Z-18		146314-0-00	E-10	
116112-0-01	A-41		144875-0-01	E-26- 3		145971-0-01	B-62		146327-0-01	B-17	
116662-0-03	C-30		144876-0-01	E-26- 2		145986-0-01	B-10		146333-0-01	B-16	
116794-0-01	E-22		144878-0-01	E-26- 4		145990-0-01	Z-28		146366-0-01	B-11	
118558-0-01	C-44		145153-0-01	A-37- 8		146003-1-01	Z-14		146367-0-01	E-30-10	
118559-0-01	C-53		145157-0-01	D- 1		146004-0-01	Z-15		146985-0-01	E-30-14	
118761-0-00	B-50		145277-1-03	Z-29		146036-1-01	E-30-12		146986-0-01	K- 7	
118764-0-02	U-23		145446-0-01	A-37- 6		146037-0-01	E-30- 7		147060-0-01	Z-11- 8	
118837-0-01	Z- 3			U-12		146038-0-01	E-30-11		147141-0-01	K- 2	
140004-0-01	B- 8- 8		145454-0-01	A-33		146039-0-01	D-30- 1		147197-0-01	D-22	
140356-0-01	Z-10		145455-0-01	A-26		146039-0-01	K-11		147198-0-01	D-17	
140378-0-01	B-38		145459-1-01	B-24		146040-0-01	E-30- 1		147245-0-01	(B-62)	
140381-0-01	B-45		145461-1-01	B-35		146049-0-01	Z- 5		147337-0-01	B-54	
140407-0-01	D- 6		145465-0-01	B- 8- 6		146055-0-01	A-24		147496-0-00	E- 9	
140480-0-01	E-30- 5		145468-0-01	B- 5		146056-0-01	A-16		147500-0-00	C- 2	
140503-0-01	D-30- 8		145472-0-01	D- 3		146058-0-01	A-19		147512-0-00	C- 3- 3	
140518-0-01	E-30- 2		145474-0-01	D-16		146059-0-01	A-20		147503-0-01	C-16	
140538-0-00	L- 1-18-2		145475-1-01	D-22		146060-0-00	A-21		147504-0-01	C-19	
140539-0-00	L- 1-18-5		145476-0-01	D-25		146069-0-01	E-30-12		147505-0-01	C-23	
140540-0-00	L- 1- 4		145478-0-01	D-19		146078-0-01	A- 4		147506-0-01	C-42	
140542-0-01	L- 1-18-4		145479-0-01	D-27		146079-0-01	H-12		147508-0-01	C-36	
140543-0-00	L- 1-18-6		145480-0-01	D-26		146080-0-00	F-19		147509-0-01	C-13	
140553-0-01	B- 3		145481-0-01	D-28			H- 1		147510-0-01	C-52	
140627-0-01	J-22		145482-0-01	D-10			H-28		147511-0-01	B-25	
	K- 6		145483-0-01	D-13		146081-0-01	H- 3		147514-0-01	D- 7	
140643-0-00	H-29- 3		145486-0-01	C- 3- 2		146082-0-00	H- 2		147538-0-01	U- 1-15	
140647-0-01	F-20		145502-0-01	C- 9		146084-0-00	H- 2- 3		147539-0-01	U- 1-17	
	H-23		145506-0-01	C- 7		146086-0-01	H- 6		147540-0-01	U- 1-16	
140668-0-01	K- 8		145516-0-01	B-41		146087-0-01	H- 8		147542-0-01	U- 1-21	
140678-0-00	L- 1- 5-5		145517-0-01	B-59		146088-0-01	H-10		147547-0-01	U- 1-24	
140682-0-01	L- 1-18-1		145519-0-01	A-37- 4		146089-0-01	H-11		147548-0-01	U-18	
140726-0-00	B-30		145520-0-01	A-37- 8		146090-0-01	H-13		147549-0-01	U- 1	
140885-0-02	A-10		145522-0-01	A-35		146091-0-01	H-15		147551-0-01	B- 8	
140948-0-01	L- 2- 1		145523-0-01	A- 4		146092-0-01	H-19		147568-0-01	U- 1- 3	
140950-0-00	L- 2- 4		145524-0-01	A-43		146093-0-01	H-17		147573-0-01	C- 4	
140957-0-01	Z-23		145525-0-01	B- 4		146094-0-01	H-22		147598-0-01	C-25	
141207-0-01	D- 9		145527-0-00	A- 5		146095-0-00	H- 5		147628-0-01	C- 3	
141208-0-01	D- 8		145528-0-00	A-27		146097-0-00	H- 5- 2		147697-0-01	F-30	
141542-0-01	F-35		145529-0-00	E-11		146103-0-01	J- 3- 4		147705-0-01	A-17	
	Z-26		145534-0-01	E-23		146104-0-00	J- 3- 3		147754-0-01	J- 5	
142037-0-00	L- 1-18-7		145543-0-01	E- 8		146105-0-00	J- 2		147756-0-01	J- 3	
142038-0-01	L- 1-18-8		145547-0-01	E- 5		146118-0-00	J-10		147764-0-01	H-33	
142268-0-01	H-24		145558-0-01	U- 1- 6			L- 1-24-4		147767-0-01	C-35	
142274-0-01	A-44		145567-0-01	U- 5		146120-0-01	H-26		148043-0-01	U- 1-18	
142349-0-00	L- 1- 5-2		145570-0-01	U-15		146121-0-00	H-29		148044-0-01	U- 1- 8	
142443-0-01	Z- 2		145571-1-01	U-11		146124-0-01	H-33		148045-0-01	U- 1-14	
142708-0-00	B-39		145573-0-00	D-29		146125-0-01	H-31		148046-0-01	U- 1-20	
142709-0-00	B-43		145580-0-01	D-20		146126-0-01	H-34		148047-0-01	U- 1-19	
142746-0-02	C-10- 5		145585-1-01	B-52		146127-0-01	H-34- 1		148048-0-01	U- 1-11	
142747-0-02	C-10- 6		145596-0-01	F-22		146128-0-00	H-34- 2		148049-0-01	U- 1- 7	
143488-0-01	L- 2- 6			J- 9		146148-0-01	J-19		148050-0-00	U- 1- 5	
143489-0-01	L- 2- 5			L- 1-24-3		146149-0-01	J-21		148051-0-01	U- 2	
143549-0-00	F-17- 5-3		145597-0-01	G- 7		146153-0-01	J-23		148350-1-01	B-56	
	H- 5- 4		145608-0-01	F-34		146156-0-01	J-16		148823-0-01	B-36	
	H-29- 2			Z-25		146157-0-01	K- 3		148825-0-01	G- 6	
	J- 3- 5		145610-1-01	F-32		146160-0-01	L- 2		148846-0-01	B-52	
	L- 2- 3		145611-0-00	F-33		146171-0-00	L- 1- 3		148848-0-01	E-26- 5	
	L- 1- 24-2		145617-0-01	F-47		146187-0-00	F-33		148849-0-01	E-26- 6	
143882-0-01	Z-20		145621-0-01	F-48		146188-0-01	B-61		148965-0-00	B-21	



Parts No.	Ref. No.	Remark	Parts No.	Ref. No.	Remark	Parts No.	Ref. No.	Remark	Parts No.	Ref. No.	Remark
149118-0-01	F-17-20		150180-0-00	Z-11-10		211528-0-01	N- 6- 3		218861-0-01	N- 6-15	
149083-0-01	C-26		150181-0-01	Z-11-14-2			N- 6-44-15		218861-0-02	N- 6-17	
149085-0-01	C-32		150182-0-00	Z-11- 9			N- 6-78		218861-0-03	N- 6-18	
149086-0-01	C-29		150189-0-01	Z-11-14-1			N-10		218862-0-01	N- 6- 8	
149087-0-01	C-28		150193-0-01	Z-11- 4		212251-0-01	K-12- 2		218863-0-01	N- 6- 1	
149088-0-01	C-27		150202-0-01	Z-11- 6-2		212544-0-01	N- 6-98-25		218864-0-01	N- 6-49	
149089-0-01	J-11		150340-0-00	E-24		213646-0-01	N- 5		218865-0-01	N- 6- 4	
149094-0-01	J-12		150342-0-01	C-37		213650-0-01	N- 2		218866-0-01	N- 6-47	
149095-0-01	J-13		150352-0-00	F-17-25		213748-0-01	N- 6- 7		218867-0-01	N- 6-48	
149104-0-01	F-50		150375-0-01	F-17		213750-0-00	N- 6-51-3		218870-0-01	N- 6-44-2	
149105-0-00	F-49		150551-0-00	A-39		213752-0-01	N- 6-25		218871-0-01	N- 6-37	
149106-0-01	F-51		150757-0-01	C-25		213757-0-02	N- 6-80		218872-0-01	N- 6-39	
149108-0-01	F-17- 5		151181-0-01	J- 3		213760-0-01	N- 6-94		218873-0-00	N- 6-40	
149110-0-01	F-17- 4		151183-0-01	H- 5		213765-0-01	N- 6-23		218874-0-01	N- 6-21	
149111-0-01	F-17-13		151185-0-01	H-29		213792-0-01	N- 6-16		218875-0-01	N- 6-22	
149112-0-01	F-17-14		151320-0-01	C-10- 3		213794-0-01	M- 1-12		218876-0-01	N- 6-72	
149113-0-01	F-17-12		151507-0-01	C-10- 4		213802-0-01	N- 6-35		218877-0-01	N- 6-51	
149114-0-01	F-17-11		151508-0-01	C-10- 4		213913-0-01	N- 6-98-10		218878-0-00	N- 6-51-7	
149115-0-01	F-17-17		151601-0-02	C-12		214002-0-01	N- 6-98-19		218879-0-01	N- 6-51-8	
149119-0-01	F-17-21		151602-0-02	A-12		214344-0-01	M- 2		218881-0-01	N- 6-74	
149120-0-01	F-17- 6			F-17-22		214897-0-01	N- 6-43		218882-0-00	N- 6-52	
149121-0-01	F-17- 8		151603-0-02	B-51		215080-0-01	G- 2-10		218884-0-00	N- 6-85	
149125-0-01	F-44		151604-0-01	B-29			G- 2-16		218885-0-01	N- 6-82	
149123-0-01	F-45			C- 4- 3			M- 1- 2		218891-0-01	N- 6-83	
149124-0-01	F-40		151606-0-01	B-22			M- 1-10		218892-0-01	N- 6-84	
149127-0-01	F-15			B-31- 2			N- 6-58		218893-0-01	N- 6-67	
	F-41			B-38- 1			N- 6-98-11		218894-0-01	N- 6-66	
149128-0-01	F-28			B-38- 4			N- 6-44- 6		218895-0-01	N- 6-64	
149130-1-01	F- 8			B-45- 2		215083-0-01	G- 2- 2		218896-0-00	N- 6-62	
149131-0-01	F-16			B-45- 4		215387-0-01	M- 1-25		218902-0-01	N- 6-59	
149132-0-01	F- 9		151606-0-01	C-41		215491-0-01	N- 8		218903-0-01	N- 6-88	
149133-1-01	F-11			C-49		215822-0-00	M- 1-24		218905-0-01	N- 6-27	
149134-0-01	F- 5			C-51		216219-0-00	N- 6-54		218907-0-01	N- 6-44-4	
149136-0-01	F- 3			C-59		216225-0-01	N- 6-98- 1		218910-0-00	N- 6-44-5	
149137-0-01	F- 2		151607-0-01	B-48		216230-0-01	N- 6-98-22		218911-0-01	N- 6-44-10	
149138-0-01	F- 1		151608-0-01	U- 8		216232-0-01	N- 6-98-17		218912-0-00	N- 6-44-16	
149140-1-01	J- 7		152187-0-01	F-17		216233-0-01	N- 6-98- 4		218913-0-01	N- 6-44- 1	
149144-0-01	E-17		152188-0-01	F-17- 5		216235-0-00	N- 6-98- 6		218915-0-01	N- 6-69	
149146-0-01	E-18		180018-0-01	B-60		216236-0-01	N- 6-98-24		218916-0-01	N- 6-44-18	
149313-0-01	B- 8		181420-2-01	E-30		216241-0-01	N- 6-98- 8		218918-0-01	N- 6-44-21	
149135-1-01	F- 6		181427-0-01	D-30		216247-0-01	N- 6-92		218919-0-01	N- 6-44-22	
149539-0-01	L- 1		181430-2-01	E-30		216248-0-01	N- 6-91		218920-0-00	N- 6-44-23	
149543-0-01	L- 1-18		181476-1-01	E-26		216277-0-01	N- 6-87		218921-0-01	N- 6-44-19	
149544-0-01	L- 1-18-3		181482-1-01	C-10		216284-0-00	N- 6-44-14			N- 6-98- 2	
149545-0-01	L- 1-24		181632-1-01	C-10		216286-0-01	N- 6-44- 9		218922-0-01	N- 6-44-17	
149547-0-00	L- 1-12		181634-0-01	A-37		216299-0-01	N- 6-44- 7		218923-0-01	N- 6-98	
149548-0-01	K- 4		181635-0-01	A-37		216300-0-01	N- 6-44- 8		218924-0-01	N- 6-98-3	
149571-0-01	J-25		181639-0-01	E- 1		216332-0-01	G- 4		218925-0-01	N- 6-98-20	
149573-1-01	J-18		181916-0-01	B-31		216345-0-00	M- 1-14		218926-0-01	N- 6-98-16	
149578-0-00	E-30- 6		181919-0-01	D- 4		216346-0-01	M- 3		218927-0-01	N- 6-98-21	
149580-0-01	E-30- 4		181934-0-01	C- 1		216351-0-00	M- 1-15		218928-0-01	N- 6-96	
149581-0-01	E-30- 4		181935-0-01	C-24		216364-0-00	M- 1-22		218929-0-01	N- 6-95	
149709-0-01	F-31		181941-0-01	C-57		216373-0-01	M- 1- 1		218930-0-01	N- 6-71	
149710-0-01	F-36		181995-0-01	B-42		216380-0-01	N- 6-79		218931-0-01	G- 2	
149712-0-01	F-37			B-49		216837-0-01	N- 6-90		218944-0-01	G- 3	
149722-0-01	F-17-18		200084-0-02	N- 6- 5		216870-0-01	M- 1- 7		218945-0-01	N- 6-98-5	
149723-0-01	F-17-19		206154-0-01	N- 6-36		216880-0-01	G- 2-13		218946-0-01	N- 6-98-7	
149724-0-01	F-17-26		206337-0-02	N- 6- 93		216905-0-01	M- 1-23		218947-0-01	N- 6-98-23	
149725-0-01	F-24		206755-0-00	L- 1-23		216921-0-01	N- 7		218951-0-01	N- 6-14	
149726-0-01	F-42		210240-0-01	N- 6-77		217093-0-01	G- 2- 7		218952-0-01	N- 6-81	
149775-0-01	F-14		210421-0-00	N- 6-51-6		217169-0-00	N- 6-50		218953-0-01	G- 2- 8	
149998-0-00	E-20		210938-0-01	N- 6-32		217249-0-00	M- 1-22		219235-0-01	N- 6-44-4	
149999-0-00	E-21		210940-0-00	N- 6-31		217280-0-01	N- 6-44-20		219405-0-01	N- 6-75	
150106-0-01	Z-11- 6		210941-0-02	N- 6-41			N- 6-65		219483-0-01	N- 6-34	
150139-0-01	Z-11-14			N- 6-51-2		217805-0-01	N- 6-35		219484-0-00	N- 6-34	
150150-0-01	Z-11		210942-0-02	N- 6-42		218819-0-01	M- 1- 3		219485-0-00	N- 6-34	
150172-0-01	Z-11- 5			N- 6-51-1		218821-0-01	M- 1-21		219486-0-00	N- 6-14-13	
150173-0-01	Z-11- 6-1		210948-0-01	N- 6-51-5		218823-0-01	M- 1- 5		219487-0-00	N- 6-44-13	
150177-0-01	Z-11-13		210965-0-01	N- 6-24		218831-0-01	N- 6-20		219488-0-00	N- 6-44-13	
150179-0-01	Z-11- 7		210973-0-01	N- 1		218860-0-01	N- 6-63		219497-0-01	N- 6	

Parts No.	Ref. No.	Remark	Parts No.	Ref. No.	Remark	Parts No.	Ref. No.	Remark	Parts No.	Ref. No.	Remark
219499-0-01	N- 6-44										
219501-0-00	M- 1- 4										
219505-0-00	M- 1- 4										
219507-0-00	N- 6										
219509-0-01	N- 6-44										
219698-0-01	M- 1-19										
219699-0-01	M- 1-20										
219726-0-01	N- 6										
219728-0-00	N- 6-34										
219729-0-01	N- 6-39										
219730-0-01	N- 6-44										
219731-0-00	N- 6-44-13										
219733-0-01	N- 6										
219734-0-00	N- 6-34										
219735-0-01	N- 6-44										
219736-0-00	N- 6-44-13										
219744-0-00	M- 1- 4										
219745-0-01	M- 1-11										
219746-0-01	M- 1- 9										
219749-0-01	M- 1- 4										
219752-0-01	M- 1-20										
219791-0-01	N- 6										
219792-0-00	N- 6-34										
219934-0-01	N- 6										
219935-0-00	N- 6-34										
219967-0-01	N- 6										
219968-0-00	N- 6-34										
219972-0-01	N- 6										
219973-0-01	N- 6-44										
219984-0-01	N- 6										
219985-0-00	N- 6-34										
219986-0-01	N- 6-44										
219987-0-00	N- 6-44-13										
220001-0-00	M- 1- 4										
220007-0-01	M- 1-19										
220010-0-01	M- 1-11										
220965-0-01	M- 1										
220966-0-01	M- 1										
220967-0-01	M- 1										
220968-0-01	M- 1										
220969-0-01	M- 1										
220970-0-01	M- 1										
220971-0-01	M- 1										
220972-0-01	M- 1										
220974-0-01	M- 1										
220975-0-01	M- 1										
220976-0-01	M- 1										
220977-0-01	M- 1										
221051-0-01	M- 1										
290439-0-00	N- 6-53										
149135-1-01	F- 6										
216922-0-01	N- 7										
216923-0-01	N- 7										
216924-0-01	N- 7										
216925-0-01	N- 7										
217135-0-01	N- 7										
217136-0-01	N- 7										
144222-0-01	Z-30										





117-715  
195715-0-02  
December, 197



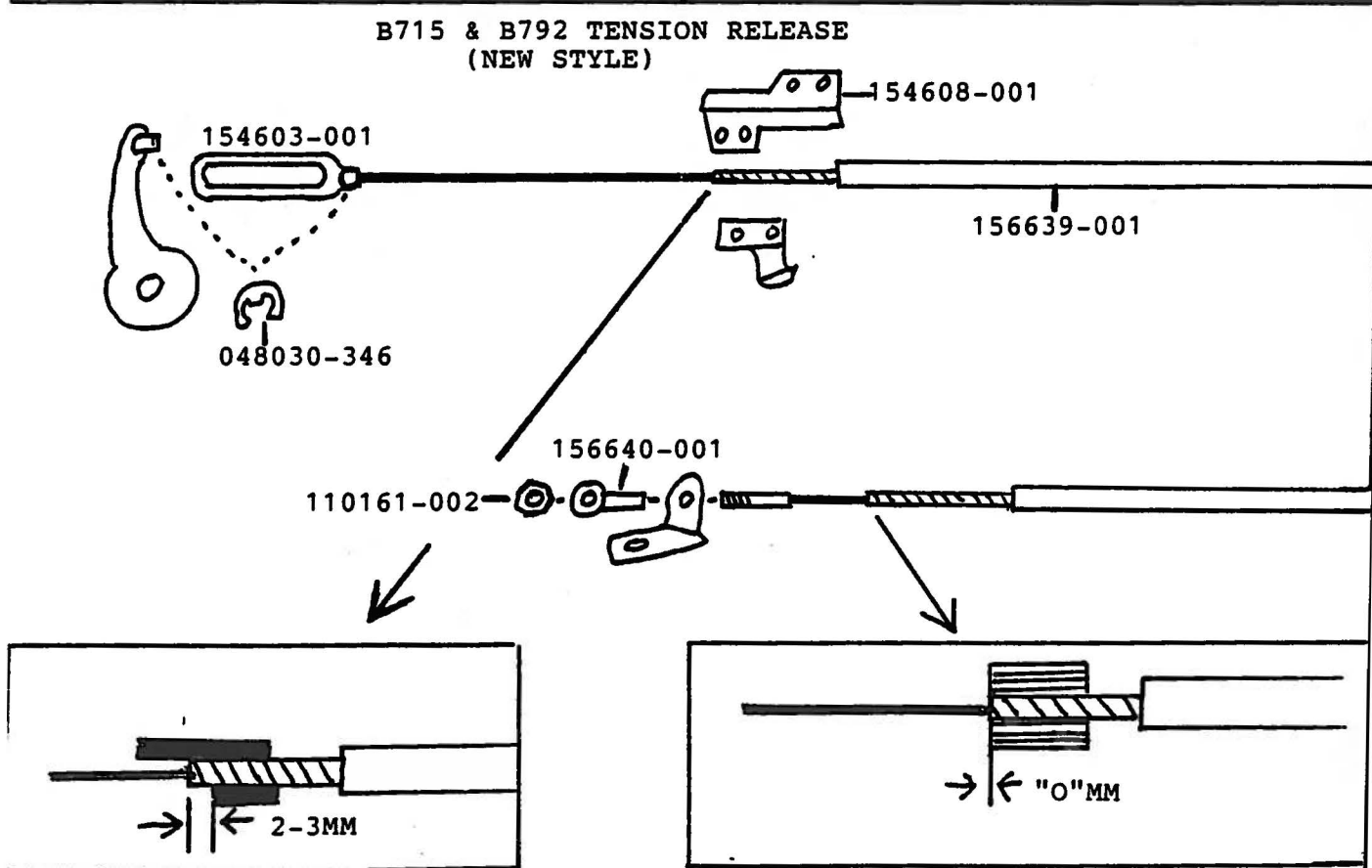
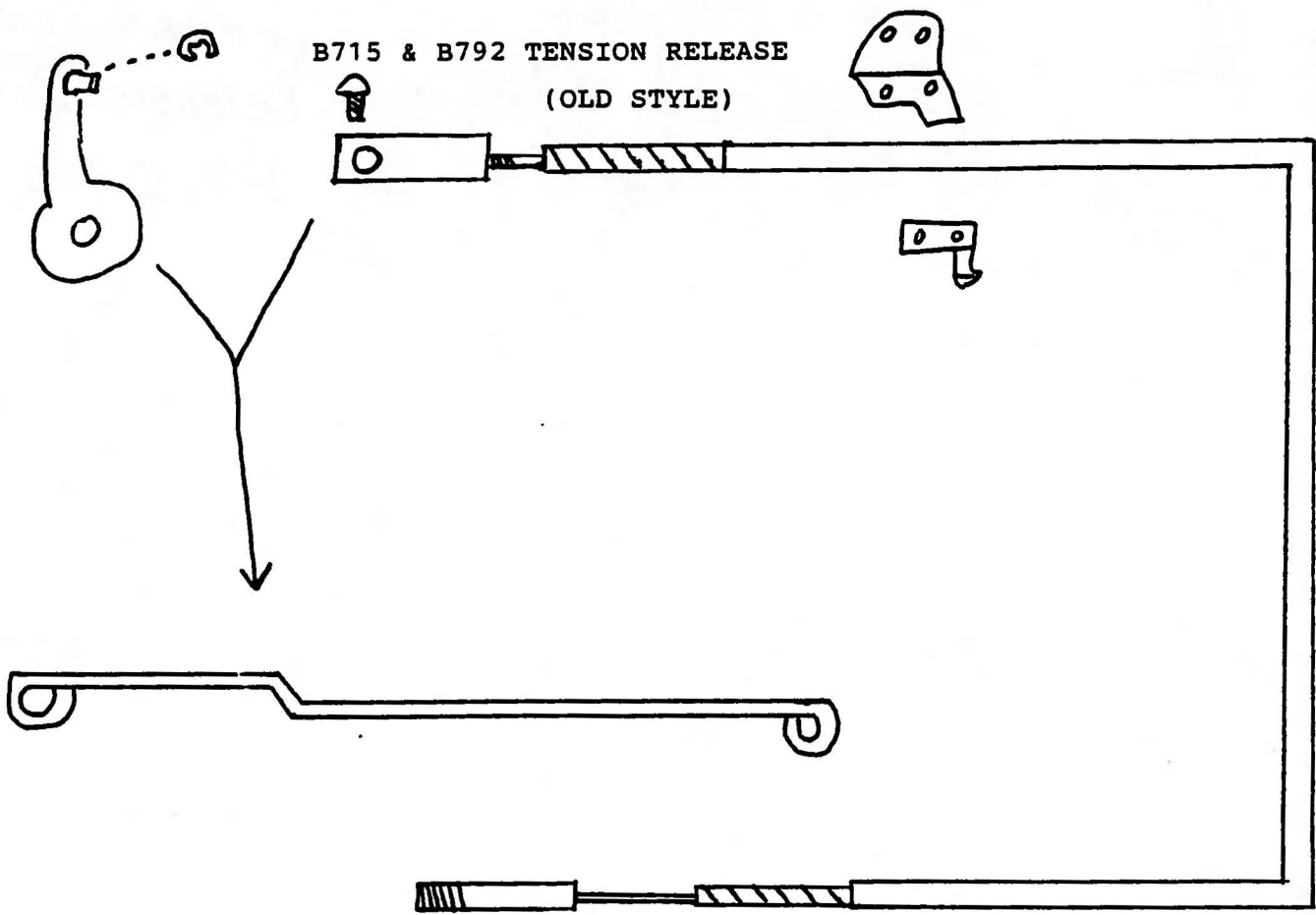

NEW  
THREAD TENSION  
RELEASE DIAGRAM  
B715 & B792